

Managing Richardson's Ground Squirrels

The Richardson's ground squirrel is commonly called the prairie gopher, yellow gopher, flicker tail or picket pin. It was named after the naturalist John Richardson who first collected specimens of the rodent in the early 1820's.

Status and importance

Ground squirrels play an important role in the ecology of Alberta's wildlife. Ground squirrels are a major source of food for many predatory birds, mammals and reptiles. One species of raptor, the ferruginous hawk, depends almost entirely on ground squirrels to fledge their chicks. Similarly, many other species rely on ground squirrels as a major food source.

The population status of Richardson's ground squirrels varies from year to year but is generally rated as "not at risk." Richardson's ground squirrels are also unregulated, which means they can be lawfully shot, trapped or otherwise removed where permitted.

Life history

The Richardson's ground squirrel is a burrowing rodent found throughout most of the prairie and parkland regions of Alberta (Figure 1). It is the most common ground squirrel of the five species found in Alberta. The other species are Franklin's (bush gopher), Columbian, thirteen-lined and golden-mantled. The Richardson's ground squirrels are the most prevalent colony dwellers of the five species.



Figure 1. Richardson's ground squirrel

Richardson's ground squirrels spend the majority of their life underground. In their underground burrow system, they usually mate, raise their litters for the first 28 days and avoid predators (except weasels and badgers) and inclement weather (heat, cold and rain). They sleep underground from just before sunset until shortly after sunrise and hibernate for up to eight months in their burrows.

Each adult female owns at least one burrow system that has five to seven exits and two to five sleeping chambers, one of which is used for rearing young. Vacated burrow systems are soon taken over by dispersing Richardson's ground squirrels. Occasionally badgers, burrowing owls, foxes or coyotes may use ground squirrel burrows.

Reproduction

Both males and females are reproductively mature the year following their birth. Mating occurs only in spring, shortly after females emerge from hibernation. A female that fails to become pregnant or loses her embryos or infants is incapable of breeding again until the following year.

Females are fertile for only two to three hours on one afternoon on one day each year and will mate with several males during that time. Males also copulate with several females. Only one litter per female is produced each spring.

A litter of 6 to 8, with an equal number of males and females, is born underground after a 23-day gestation. At birth, the infants are naked, blind, helpless and totally dependent on their mother. At first emergence aboveground, when four weeks old, juveniles immediately begin eating solid food and rapidly become nutritionally independent of their mother.

Litter size often varies with the quality of vegetation available, averaging between five to six young on native pasture and expanding up to nine or ten on tame forage crops.

During June and July, most of the young ground squirrels seek new areas to establish colonies as far as 3 km away. Ground squirrels vigorously defend their burrows and foraging area from other ground squirrels.

Life span

Natural mortality among Richardson's ground squirrels is quite high, particularly in males. As a result, the sex ratio among adults is about four females for each male. Females live about four years (maximum six), on average, while males usually live only one year (maximum two to three).

The major cause of death is predation and starvation; only half the females and less than one fifth of the males born each year will reach adulthood.

Hibernation

Richardson's ground squirrels have evolved to escape the prolonged winter period by hibernating, a torpor-like state in which the body temperature drops while heart and respiration rates slow down dramatically.

To survive without food or water for periods exceeding 210 days, ground squirrels need to consume vast amounts of food high in energy to develop a reservoir of body fat. Adult males enter hibernation sometime in late July, females several weeks later followed by juveniles until freeze-up.

Each animal hibernates alone in a special chamber (called the hibernaculum) that it prepares up to four to six weeks in advance, but does not use until ready to hibernate. The

hibernaculum is sealed off with a soil plug. The only predator capable of getting into the hibernaculum is the badger.

Males emerge from hibernation from late February to mid-March while females come out about two weeks later.

Social behavior

Richardson's ground squirrels live in groups of closely related female kin. Females live their entire life in or near their birth site, but males of the year tend to disperse and leave their birth area after weaning.

As soon as the female is pregnant, she will not tolerate males, including her mate(s). Females will only tolerate their female relatives (i.e. mother, grandmother, daughters, etc.) and are aggressive to all other squirrels. Females recognize their kin throughout life, even after many months without contact during hibernation.

Each female rears her litter by herself with no assistance from male or female relatives. Males do not form any social associations, either with other males or with females.

Diet

Richardson's ground squirrels eat a wide variety of food. Most prefer succulent green vegetation such as grasses, forbs, young shrubs and seeds. Richardson's ground squirrels occasionally eat insects and scavenge road-killed ground squirrels, but they very rarely kill for food.

Little is known about the preferred natural diet of Richardson's ground squirrels, but the assumption is the relatively high nutrient and oil content of seeds helps in the deposition of fat necessary for hibernation. Richardson's ground squirrels are also known to store quantities of food in burrows. Males store seed in the hibernating chamber while females do not store seeds.

Weight

The body weight of Richardson's ground squirrels increases dramatically through the spring and summer months and can double during this period. Adult males weigh about 500 gm (1 lb) by fall and females about 350 gm (3/4 lb).

Ground squirrel damage

Damage caused by Richardson's ground squirrels ranges from causing an occasional headache for some to a significant loss of crop production to others.

The most common types of ground squirrel damage are crop loss through direct consumption and reduced production due to plant injury and trampling. In addition, downtime and repair costs due to damage to hay binds as well as physical injury to livestock with ground squirrel burrows and those of badgers are also major concerns.

Burrowing activity in green spaces such as ball diamonds, golf courses and cemeteries as well as the risk of an air strike because of large birds attracted by ground squirrels at airports are serious problems for urban managers.

Despite decades of conflicts with ground squirrels, the extent, causes and magnitude of ground squirrel damage have never been fully investigated. This information shortfall has greatly impeded the development of effective, long term control measures.

An in-depth analysis of the causative and associated dynamics of ground squirrel damage as well as a thorough understanding of the biology and behaviour of the animal are vital for the development of a sustainable, long term, affordable and appropriate management strategy.

Managing ground squirrels

The poison controversy

The most common control response to ground squirrel damage is to set out poisoned food-based baits. This approach has long been the recommended standard control since poisons are convenient to use and reasonably cheap, while the results are obvious and reasonably rapid.

However, studies have shown that for overall long term effect, food-based poisons are a poor choice. Control with this approach is only short term, and re-invasion usually occurs fairly quickly, so the poisoning process must be repeated.

In addition, poisoned baits are relatively restricted because they produce the best results during the short period at spring green-up. Consequently, poisons are not a good option during the heaviest demand in the summer when the young rodents have emerged aboveground. It has been demonstrated that repeat poisoning during the same season often results in bait shyness, where squirrels learn to avoid the poison.

Further, many of the acute poisons, such as strychnine, are under continuous scrutiny for human and environmental safety reasons, subjecting them to potential changes in

use-pattern restrictions. Such changes will inevitably result in reduced performance and reliability in the field. Therefore, it is imperative that all poison baits be used properly and in accordance with label instructions.

Integrated pest management model

Alberta Agriculture and Rural Development strives to seek permanent, pro-active solutions and strategies to manage ground squirrel damage. This approach includes the development of an integrated pest management (IPM) strategy for Richardson's ground squirrels.

Due to the continual concern for human and environmental safety, pesticides such as rodenticides (for the control of rodents) will face closer criticism and potential restrictions on their use. Inevitably, some of these products will be de-registered. Given this uncertain future, other management strategies need to be developed and put in place to provide effective alternative strategies to manage ground squirrel damage.

The IPM strategy consists of many components that include a wide variety of input considerations to produce an overall beneficial effect with minimal environmental effect and risk to human safety.

The greatest IPM benefit occurs when several techniques or strategies are used in conjunction and on a continuous basis. The IPM model is designed to produce long term, sustainable management of ground squirrel damage, and it requires a variety of inputs.

1. Assessing ground squirrel damage

One of the fundamentals for long term damage control is the assessment: what is the damage and what are the actual direct costs. This assessment includes downtime and time lost to repair equipment, crop production and yield loss, soil rehabilitation and weed control.

2. Monitoring ground squirrel numbers

A major building block for both assessing damage and developing long term management plans is estimating rodent numbers. This estimate also helps determine if, when, where and what type of management tool to employ when numbers reach certain levels.

For instance, a ground squirrel colony in a field may remain small for several years and not cause any appreciable damage, so the landholder may be tolerant and not use any controls. However this assessment cannot be done without regular and accurate monitoring. Monitoring, therefore, can save valuable time and effort that might be put into direct management efforts.

Conversely, when populations expand and disperse rapidly, the landholder should take remedial action because the population may have surpassed its economic threshold (the point at which it is cost effective to employ control methods).

There are several ways to estimate ground squirrel numbers. A popular monitoring technique is the combination of electronically recorded stress calls and visual counts where ground squirrels respond physically, vocally or both.

One aspect of this technique is to visually count the number of squirrels in a 100 m by 100 m area that respond to a hand-held imitation ground squirrel call. Within this area, 5 Richardson's ground squirrels counted prior to young emerging or 20 ground squirrels counted after emergence of young are considered heavy populations.

Another good technique for estimating ground squirrel numbers is to count the active mounds within 1 m as you walk 100 m. One active mound per 2 strides over 100 m is considered a heavy population.

The best method of estimating Richardson's ground squirrel densities is to live trap squirrels in a set area for one day and compare that number to previous capture numbers for the same area. This difference will indicate an increase or decrease in population numbers. Comparison of capture numbers needs to be done at the same time of the Richardson's ground squirrel cycle under similar weather conditions.

3. Forecasting ground squirrel numbers

Little or no information exists as to how and why ground squirrel numbers fluctuate and what triggers their dispersal. Such information would be helpful in assisting landholders to predict population changes and, in turn, determine what type of management strategy(s) should be implemented at any point. It is known that dry conditions magnify the fluctuations in Richardson's ground squirrel populations.

4. Action and economic thresholds

The **action threshold** is the population size of a colony of ground squirrels that will require remedial action to prevent any increase that could result in unacceptable economic loss.

The economic threshold is the population size of a colony that will require immediate management because the size is known to exceed the point where it will cause unacceptable economic loss to the landholder. One active mound per 4 strides or 20 per cent crop damage over 100 m is a concern for possible control measures.

Cultural Control

Humans came into conflict with several species of animals following the settlement and subsequent cultivation of the prairies. Although many animals were driven off the prairies, Richardson's ground squirrels survived despite early efforts at extermination. These ground squirrels are now found on almost all man-altered landscapes, from cultivated farmland to finely manicured golf courses throughout the animal's natural range.

Some research has been conducted on the effects of tall vegetation (over 30 cm) on ground squirrel movement. The data, while sketchy, indicates that squirrels avoid tall vegetation stands, preferring more open grass fields. This finding means that medium to high vegetation could be useful in preventing or slowing down ground squirrel invasion.

The use of raptor (hawk and owl) platforms, nest boxes and perches close to ground squirrel colonies will also help reduce their numbers and will limit colony growth and expansion. One platform per quarter section is adequate in areas of limited trees as raptors are quite territorial. Platforms need to be at least 10 feet high and having 2 big round bales standing on end has attracted raptors to nest.

Biological control measures

Natural attrition

Richardson's ground squirrels are prey for many ground and avian predators that include coyote, fox, badger, skunk, weasel, crow, magpie, raven, owls and most large birds of prey.

Many predators rely on ground squirrels as an intermediate food source while some, like the ferruginous hawk, depend almost entirely on this single food source to fledge their chicks.

Juvenile male squirrels make up most of the available food source for predators; up to half are lost to predation alone. Although females are also killed by predators, their mortality rate is somewhat lower than males due to their differences in territorial behaviour.

While natural attrition accounts for a good portion of ground squirrel mortality, the overall effect in reducing damage is not significant. Even so, encouraging natural predators onto or near ground squirrel colonies is worthwhile.

Retaining isolated patches and corridors of vegetation for ground nesting birds and mammals as well as erecting artificial platforms for aerial nesters will always help.

Promoting vegetation growth around or near watercourses, fencelines, sloughs and other natural locations will also encourage natural predators.

Fertility

Recent developments in the field of immuno-contraceptives have positive implications for managing ground squirrels. Where numbers are high, ground squirrel populations can be stabilized and controlled at or below action or economic thresholds through the use of contraception and sterilization technology.

Much work is still needed to develop this type of technology, but the concept of managing and maintaining ground squirrel populations through fertility agents has a promising future.

Lethal control

Four methods of lethal control are recognized:

- poison
- trapping
- fumigation
- shooting

Acute poisons

Read instructions carefully and always follow directions for use of all poisons. Only use registered control products.

The only two acute poisons registered for ground squirrels are strychnine alkaloid and zinc phosphide. These poisons are called acute (single dose poisons) because a lethal dose is available in a single meal.

Strychnine causes death by interfering with the central nervous system, resulting in muscle spasms that lead to respiratory failure and death.

Zinc phosphide causes death due to asphyxia from the production of phosphine gas (PH₃) in the victim's stomach. Zinc phosphide can be absorbed in small amounts through the skin, so rubber gloves should be worn when handling this bait.

Strychnine alkaloid (0.4 %) and zinc phosphide (2.0 %) are registered as restricted or commercial baits for ground squirrel control and have certain use restrictions. Check with the vendor for use restrictions before purchasing these products.

Carefully read and follow label directions. Poisoned grain must be placed below the ground surface within the entrance of the burrow or placed in a secure bait station. The prescribed amount of bait should be placed well

within each active burrow entrance. Burrows will usually have several entrances, so every opening need not be baited.

Baits must be set out and properly monitored; otherwise, ground squirrels may not consume a lethal amount and will only be temporarily poisoned and quickly recover. In such cases, ground squirrels will associate their illness with the bait and will avoid further food baits.

Always ensure that sufficient bait has been placed. The greatest success in poison baiting occurs during the first 24 hours and quickly tapers off. This tapering-off happens primarily because not every animal in the colony will seek, find and eat a lethal dose of the bait, and some may not have any desire to eat the bait at the time of discovery.

Repeated baiting with the same bait during the same year is generally unsuccessful. Therefore, baiting should be done thoroughly and correctly the first time.

Bait shyness can be prevented by pre-baiting, which means offering ground squirrels untreated grain, such as oats, for several days before baiting to get them used to the food bait. Pre-baiting ground squirrels to a "new" food improves the likelihood of their eating a lethal dose of poisoned bait. Studies have shown that pre-baiting often improves bait acceptance and, therefore, ground squirrel control. The major disadvantage to pre-baiting is the cost of labour and grain.

Only use fresh bait. Spoiled, dirty, contaminated or old bait will not be eaten by ground squirrels.

Anti-coagulant poisons

Rozol bait (chlorophacinone) is an anti-coagulant bait registered for the control of ground squirrels. It may be used in both agricultural and residential areas (with some restrictions – consult with the vendor). Anti-coagulants interfere with the clotting mechanism of the blood and cause a relatively painless death from internal bleeding two to four or more days after the bait is eaten.

Anti-coagulant poisons are prepared in several grain bait formats such as extruded pellet, paraffinized block or loose meal. These poisons are also available in a liquid concentrate for convenient mixing with grain.

For anti-coagulants to be effective, ground squirrels must consume more than one meal over a two- or three-day period. Thus, the control period is considerably longer than with acute poisons and, as such, more costly and time consuming. Also, ground squirrels will continue to consume bait (and damage crops) even after they have ingested a lethal dose. It is believed that anti-coagulant baits do not cause bait shyness.

One advantage to anti-coagulants is that they do not pose a significant risk to non-target animals that eat the bait or poisoned ground squirrels. However raptors and other predators that prefer live prey are attracted to the poisoned Richardson's ground squirrel for the three- to five-day period before the ground squirrel dies. This extended exposure to poisoned squirrels means that birds of prey and other predators are significantly at risk when humans use anti-coagulant poisons.

Bait stations

An alternative to hand baiting or spot baiting is a bait station. Most farm retailers carry a wide variety of commercially manufactured bait stations that are affordable, durable and work very well.

If using the "T" shape style bait station, it should be placed and properly secured (use wire) to a fence post to prevent stock from rubbing it and knocking it over.

Each station should contain about 500 g (1 lb) of bait. Bait stations should be checked daily to maintain an uninterrupted supply of bait for a few weeks or until feeding ceases. One bait station will expose rodents 50 to 100 m away to the bait.

A popular homemade bait station that works well is a 1.2 to 2 m length of PVC pipe, 10 to 15 cm in diameter. Like other bait stations, these stations should be well secured to the ground to prevent spillage.

PVC inverted-T anti-coagulant bait station

You can manufacture your own bait station using PVC tubing (see Figure 2). Use PVC pipe no smaller than 10 cm in diameter for ground squirrels. The "T" long, upright end, 60 to 75 cm, is where the bait is placed. Keep this end upright by securing it to a fence post, building, tree or metal stake, etc. After filling with bait, place a plastic cap on the end to keep moisture out.

Keep fresh bait in the station at all times during the control program.

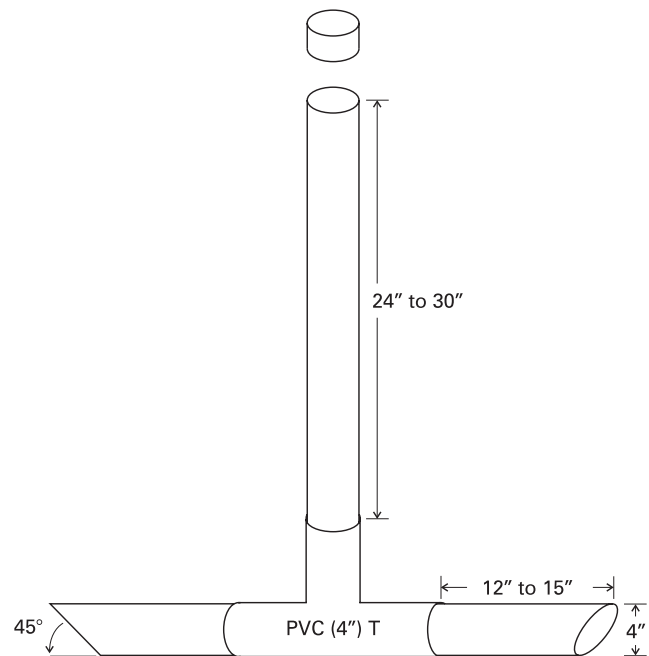

Figure 2. Commonly used inverted "T" ground squirrel bait station made of 10 cm PVC pipe – stake secures station in upright position

What bait and method should be used?

Bait type and method of use will be determined by the following considerations:

- human safety
- hazards to livestock, pets and non-target wildlife
- cost
- effectiveness of control
- appropriateness

All toxicants are potentially dangerous and should be handled with the utmost care to avoid accidental poisoning. Even though anti-coagulants are generally less hazardous than strychnine or zinc phosphide, they must be handled with care.

Most mammals and birds have a low tolerance to strychnine and zinc phosphide. Because these poisons act so quickly, they present a considerable risk to all life forms. The time from eating poison bait to sickness and death can be minutes, so speed is essential in the administration of first aid and the treatment of accidental consumption.

Rodents are more susceptible to anti-coagulant poisoning than many non-target animals, such as birds. Thus, anti-coagulants are a more appropriate control agent for Richardson's ground squirrels. The time from ingestion to death is usually three to five days for anti-coagulants,

which is sufficient time to provide proper medical attention to an accidentally poisoned pet or livestock animal.

Hazards to livestock, pets and wildlife depend almost entirely on the baiting technique. Non-target poisoning can occur by non-target animals eating the bait or eating animals that have been poisoned. Placing bait within the burrow will reduce the risk of non-target poisoning. As previously mentioned, bait stations offer a secure alternative to spot placement of bait.

Every day for a week after using poisons, conduct a thorough search to pick up dead ground squirrels. Always wear gloves and dispose of dead rodents properly (see product label).

Generally, the best time to use poison baits is just before vegetation begins to turn green in the spring, soon after males and females have emerged from hibernation. Poison baits are generally less effective during late spring and summer because ground squirrels do not readily consume grain at this time of year.

It is believed, however, that just before entering hibernation in late summer, squirrels may consume grain baits because of their dietary changes as they consume high energy foods, such as seeds, in preparation for hibernation.

Other control methods

Fumigants

Ground squirrels can be killed in their burrow systems by using one of several toxic gases called fumigants. However, fumigants are only effective if ground squirrels are present in their burrows, so fumigation should only be done early in the morning or late in the day or when the rodents are not aboveground (i.e. during cool, cloudy or rainy weather). Some fumigants work equally well during the day where ground squirrels have been seen entering their burrow.

Burrow fumigation has the advantage over other toxicants and trapping because fumigants are not linked to a specific behavioural response to achieve effective results. The downside, however, is that fumigants tend to be less selective than poison food baits. Like other control agents, fumigation is most effective soon after ground squirrels emerge from winter hibernation when their numbers are lowest.

Gas cartridges (sold as “Giant Destroyer” or “Woodchuck Bomb”) are easy to use and are available from farm, hardware or horticultural retailers. Place the lit cartridge into the entrance of the main burrow. Then, with a shovel handle or your foot, quickly cover the burrow entrance

with soil or sod and tamp tight to seal in the fumigant. For best results, seal all auxiliary holes before placing the cartridge in the burrow entrance.

Fumigants work best when soil moisture is high because gas absorption and leakage are minimal in moist soils. In loose soil, place crumpled paper in the burrow after you toss in the gas cartridge. This method will prevent dirt from covering up the gas cartridge. Do not use pyrotechnic (burning) cartridges near buildings because high temperatures and open flame may cause fires.

Phostoxin (aluminum phosphide) produces a lethal gas through the slow sublimation process of the pellet similar to that of a mothball. The downside to this method is a longer fumigation time. Phostoxin produces an almost odourless phosphine gas that quickly enters the animal’s bloodstream causing death by asphyxiation.

Due to the rapid action of aluminum phosphide, this product is most effective when used in the early evening after the squirrels have entered their burrows for the night. It is recommended that two or three pellets be placed within the main (most active) burrow entrance and quickly sealed with dirt. All nearby burrow holes do not need to be treated, but should be properly sealed with dirt. In dry soil conditions, add a piece of newspaper soaked in water to enhance gas production.

Rocon Concentrate Rodenticide is a recently developed control agent that causes death by asphyxia or drowning although it is listed as a fumigant. Rocon Concentrate is a quick expanding, soapy liquid that is introduced into the burrow from a pressurized tank through a hand-held wand. Rocon Concentrate quickly fills the entire burrow system causing the squirrels to either drown in the soapy foam or die from asphyxia.

Rocon Concentrate requires considerably more labour than other fumigants, but has excellent potential in urban areas such as residential green spaces because it contains no pesticides. Like other fumigants, Rocon Concentrate requires the same application strategy because the rodents must be present in the burrows where the product is used. Soft water or a water softener need to be used with Rocon as the detergent functions much better with soft water.

Carbon-monoxide gas from a gasoline vehicle is somewhat effective, but due to cost, its use is restricted to small areas or few rodents. Use a proper flexible gassing hose, place it deep into the burrow entrance and tamp soil around the hose to contain the gas. Seal up all holes with dirt, and gas the burrow for at least 30 minutes. Do not open holes for 24 hours.

Trapping

Although trapping is labour-intensive, it can be highly effective, particularly in small areas or where rodent

numbers are few. Trapping can be conducted any time of year, but the best results will be achieved soon after adult squirrels emerge from winter hibernation.

Always place leghold traps as deep within the burrow as possible to avoid capturing non-target animals such as birds, skunks or pets. Check traps regularly and quickly dispatch and dispose of captured squirrels.

Humane box or cage traps quickly capture ground squirrels unharmed for disposal. Be sure to place these traps on level ground so that they will not tip easily when the squirrel enters. Box traps do not require a food lure; however, when dealing with a small number of squirrels, a little peanut butter or nutmeat can be used to encourage Richardson's ground squirrels to enter the trap

Shooting

If local laws permit, shooting the ground squirrels with a .22 or varmint caliber rifle can provide good control where squirrel numbers are relatively low or the size of the infestation is small. This control method is more time-consuming but can be cost effective if recreational shooters can be employed. For safety and legal considerations, shooting is generally limited to rural, agricultural land far beyond acreage and suburban development areas.

Ground squirrels that are repeatedly shot at become hunter-shy quickly and will immediately disappear at the sight of a hunter. Rarely can one get close enough to use a pellet gun effectively, and the use of a shotgun is not recommended.

Other methods

Cultural

Once ground squirrels have been removed from a pasture or crop area, re-invasion can be reduced by cultivating their burrow systems. Crop rotation of an infested pasture is recommended.

Flammable and toxic chemicals

Flammable gases are not registered for ground squirrel control even though many have been touted as an effective method to kill ground squirrels. However, highly inflammable gases such as acetylene and propane pose a serious risk of injury or death to users and passers-by, and for these reasons, they should not be used.

Gas exploding devices or **anhydrous ammonia** or other toxic gases have not proven to be safe, reliable or effective. Studies have shown that introducing and igniting oxy-acetylene or propane/oxygen mixtures in ground squirrel burrows is not particularly effective on large-area operations.

Although no data exists on the effectiveness of anhydrous ammonia, there have been, at best, mixed results with its use. The cost, utility, practicality and labour are considered serious drawbacks to anhydrous ammonia fumigation.

The main concern with flammables and anhydrous ammonia is user and bystander safety. In fact, due to the high risk of chemical exposure, anhydrous ammonia suppliers refuse to sell their product for this control purpose.

Vacuum

Vacuum devices that suck rodents out of their burrows are regularly used in the United States for prairie dog control and may have application for ground squirrels in solid soil types. However, no reliable Alberta data exists at this time to confirm or deny the usefulness of this method of ground squirrel control.

Prepared by

Alberta Agriculture and Rural Development

For more information

Alberta Ag-Info Centre
Call toll free: 310-FARM (3276)

Website: www.agriculture.alberta.ca