



SOLAR-POWERED WATER PUMPING SYSTEMS FOR LIVESTOCK WATERING

Livestock have traditionally been turned out to pasture and allowed to walk through and drink from any slough, creek, river, lake or dugout. It is increasingly being recognized by livestock producers and other water users that allowing livestock direct access to surface water sources is a concern due to impacts on water quality and detrimental effects on the livestock itself. Livestock producers also recognize that range management is often constrained by the distribution of natural water supplies.

To provide a safe, reliable supply of good-quality water for livestock while reducing negative impacts on water quality and the environment in general, and to enhance range management, it is often necessary to convey water from the source to a remote location. However, the availability of power supplies on the open range is often limited, so some alternate form of energy is required for water conveyance. One water-conveyance option available to producers is a photovoltaic or solar-powered pump.

What is a solar-powered pump?

A solar-powered pump is a normal pump with an electric motor. Electricity for the motor is generated on-site through a solar panel which converts solar energy to direct-current (DC) electricity. Because the nature of the electrical output from a solar panel is DC, a solar-powered pump requires a DC motor if it is to operate without additional electrical components. If a pump has an alternating-current (AC) motor, an inverter would be required to convert the DC electricity produced by the solar panels to AC electricity. Due to the increased complexity and cost, and the reduced efficiency of an AC system, most solar-powered pumps have DC motors.

What happens when clouds obscure sunlight?

Solar-powered pumps will naturally work best on sunny days, which is fortunate because cattle will consume more water on hot, sunny days. But, water is still required on cloudy days. Solar panels still produce some electricity when it is cloudy, but their output is diminished. To ensure that ample water is always available for livestock, solar-powered water pumping systems should incorporate storage sufficient to supply water requirements for three or four days.

What does a solar-powered pumping unit consist of?

The components comprising a solar-powered pump depend on whether the pumping system is a direct-drive system or a battery-operated system. The following sketches illustrate the components comprising these two systems:

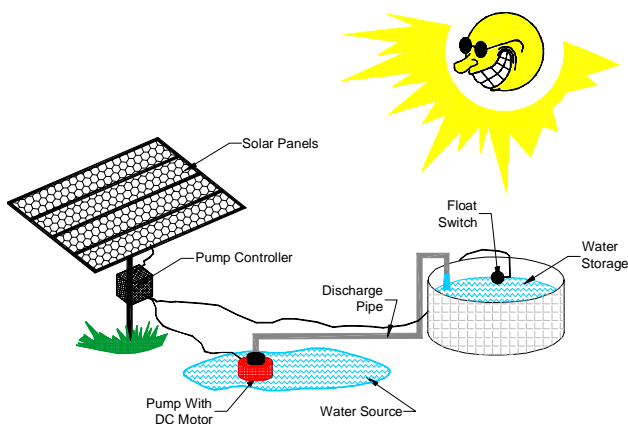

Direct-Drive System

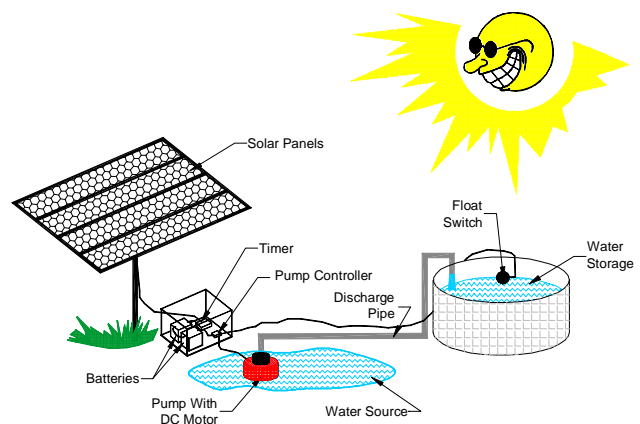

Battery System

Both systems should incorporate a water-storage facility, but the water-storage component of the battery-powered system can be reduced in size relative to the direct-drive system due to the fact that the batteries effectively provide some storage.

What other considerations are there?

For the direct-drive systems, it is important to match the power output of the solar array with the power requirements of the pump to maximize efficiency. For the battery-powered systems, it is important to use good-quality deep-cycle batteries and to incorporate electrical controls such as blocking diodes and charge regulators to protect the batteries. Some solar panels incorporate the electrical control elements.

What kinds of solar-powered pumps are commonly used?

Solar-powered pumps for livestock water supplies are available in a wide variety of configurations. If the water source is a dugout, floating pumps are available. If the water source is a well, submersible centrifugal pumps are often used. For dugouts, streams and shallow wells, self-priming surface centrifugal or positive-displacement pumps can be used. Whatever kind of pump is used, it is especially important in low-voltage applications like solar energy, that care is taken to ensure that the pump is matched to head and discharge requirements of the application.

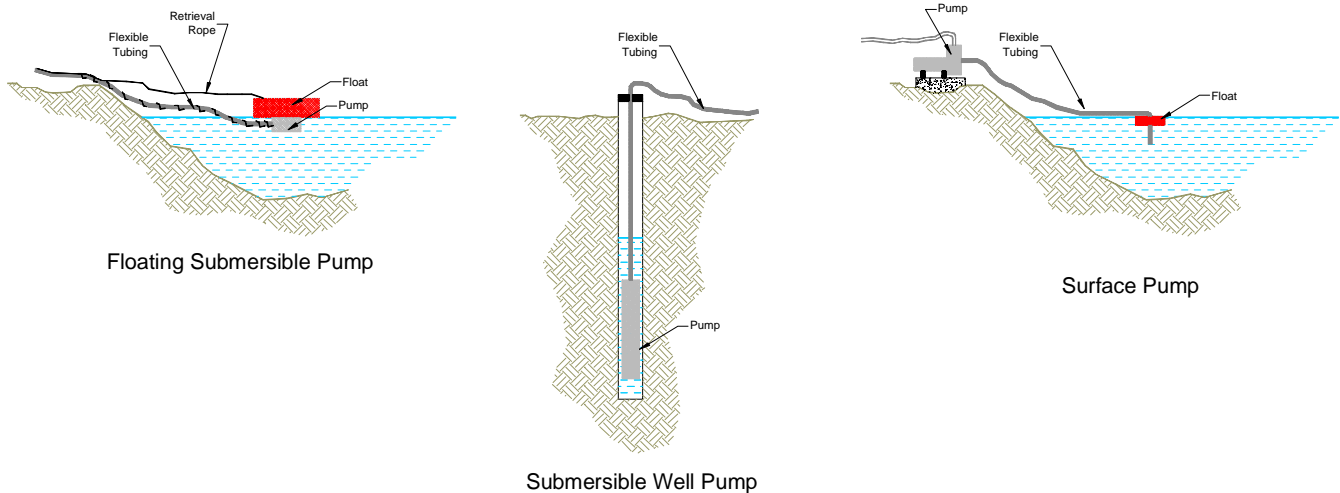

How much water can a solar-powered pump deliver?

Solar-powered pumping systems can be configured to meet a wide variety of demands. The amount of water a solar-powered pump can deliver is a function of how far the water has to be lifted, the distance it has to travel through a delivery pipe (and the size of pipe), the efficiency of the pump being used, and how much power is available to the system. Power can be increased by adding more solar panels. For example, a $\frac{1}{2}$ h.p. pump supplied by three 50-watt panels can deliver water at a rate of about $1\frac{1}{2}$ gpm to a location 30 m higher than the source. As a comparison, a 3 h.p. low-lift irrigation pump powered by an array of 60 panels could deliver water at a rate of about 1,000 gpm.

How much does a solar-powered pumping system cost, and when is it cost-effective to use one?

Generally, if the water source is further than about a kilometre from a power line, it will be less expensive to use solar power rather than extending the power line. The cost of a solar-powered pumping system will naturally vary according to its capabilities, but the cost of most systems for stockwatering applications ranges between \$2,000 and \$6,000.

What is required to maintain a solar-powered pumping system?

One of the main advantages of a solar-powered pumping system is its simplicity and durability. The pump is the only part of the system having any moving parts, and it comprises a relatively small portion of the total system cost. Unless the system is installed in an extremely dusty area, occasional inspection of the wiring and the general

appearance of the panels will be all that is necessary. Panels can be cleaned with plain water and a soft cloth. The frequency of inspection should match the amount of storage available. For example, if the system incorporates a three-day supply of water and/or energy in storage, then it should be inspected at least every three days.

What should be considered when locating and installing a solar-powered pumping system?

One of the advantages of solar-powered pumping systems is their simplicity, and because of this, they can be easily assembled and installed by the user. When a solar-powered pumping system is purchased, the supplier should supply total system designs and electrical drawings, as well as assembly, installation and set-up instructions.

The photovoltaic array (solar panels) can be mounted on a post or frame, but whatever the array is mounted on, it should be stable enough to withstand strong winds. The array should ideally be oriented toward true south, but deviations of 15 degrees east or west should not significantly affect performance. Some systems are available with devices that track the sun as it moves across the sky, but for most stockwatering applications, the increased efficiency derived from such systems is generally not worth the added cost and complexity. However, some users have found that tracking units significantly enhance the performance of direct-drive systems.

The solar panels should be tilted at an angle to horizontal to maximize power output. If the panel is to be fixed for year-round use, the tilt angle should equal the latitude of the site. If the panel mount has an adjustable tilt angle, the tilt angle should be equivalent to the site latitude minus 10 to 15 degrees in the summer, whereas in winter, the tilt angle should equal the latitude plus 10 to 15 degrees. The following sketches illustrate typical tilt angles for most mid-latitudes on the Canadian Prairies:

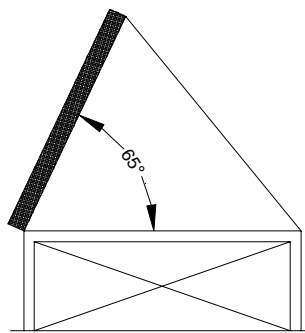

Winter

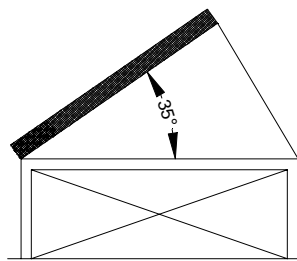

Summer

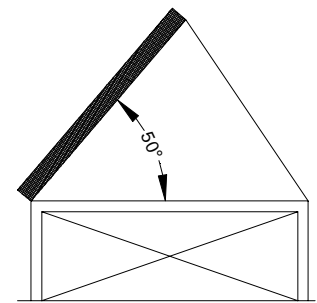

Year-Round

Batteries and electrical components should be housed in a vented, weather-proof enclosure. For late-season or winter use, the enclosure should be insulated. The solar panels and the battery enclosure should also be protected from damage that might be caused by cattle. Small solar pumping systems that incorporate two or three panels can be easily moved, which can be a major advantage for applications such as rotational grazing systems. The panels, battery-enclosure and a storage tank can all be mounted on a trailer or skid, and the pump and piping can be disconnected for transport.

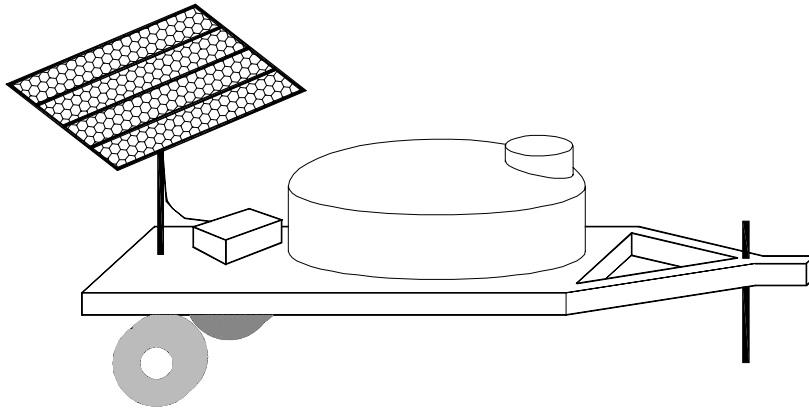

Trailer-Mounted Unit



The Bigger Picture

Solar-powered water pumping systems are just one of many options available to producers interested in managing their rangelands, providing improved water quality for their livestock and protecting their water supplies. For additional information on other livestock watering systems, as well as solar-powered water pumping systems, contact your local PFRA office.