

---

# TABLE OF CONTENTS

---

<b>Introduction</b> .....	<b>1</b>
<b>Horse Feeders</b> .....	<b>2</b>
Grain Bin.....	3
Hay Bins.....	3
Hay Net.....	4
<b>Club Banner</b> .....	<b>5</b>
<b>Hay Bag</b> .....	<b>7</b>
<b>Saddle Stand</b> .....	<b>10</b>
Saddle Stand #1.....	10
Saddle Stand #2.....	13
Saddle Stand #3.....	16
<b>Saddle Pads</b> .....	<b>20</b>
Western Saddle Pad #1.....	20
Western Saddle Pad #2.....	23
<b>Tack Covers</b> .....	<b>26</b>
Halter Cover.....	26
Additional Tack Covers.....	27
<b>Cooling Sheet</b> .....	<b>28</b>
<b>Leg Wraps</b> .....	<b>30</b>
Leg Wrap 1.....	30
Leg Wrap 2.....	31
<b>Tail Guard</b> .....	<b>35</b>
<b>Braiding Reins</b> .....	<b>37</b>
Round Braiding, Split Reins.....	37
Round Braiding, Rommel Reins.....	40
Braiding Snaffle Bit or Training Reins.....	45
<b>Mineral and Salt Feeder</b> .....	<b>49</b>
<b>Cavaletti</b> .....	<b>50</b>
<b>Hunt Seat Pads</b> .....	<b>52</b>

Double Pad ..... 52

Pad With Facing..... 53

**Making A Horse Halter ..... 56**

    Flat Braiding..... 56

    Round Braiding..... 57

    Constructing the Rope Halter ..... 58

**Tack Box..... 62**

    Small Tack Box ..... 62

    Large Tack Box ..... 65

**Project Evaluation ..... 69**

---

# INTRODUCTION

---

Winter projects are an important part of the 4-H program because many of the meetings take place when the weather does not favor outdoor activities. The following is a sample of projects that you may do with your members. Difficulty varies from project to project. For some projects, for example the saddle stand, leaders and parents may be required to direct every step. You and your members should select a project that they will be able to complete, and will be useful for the level they are participating in.

The winter projects you do should not be limited to the projects in this book. Many clubs have suitable projects that they or neighboring clubs have developed.

---

# HORSE FEEDERS

---

## Grain Bin

### Materials:

- 1 car tire any size
- 2 - 5 cm thick piece of plywood
- 5 - 10 fence staples

### Equipment:

- Hammer
- Cutting knife or heavy shears
- Pliers

### Procedure:

1. Cut the plywood into the right size and shape for the tire. It should be 5 cm wider than the tire all of the way around.
2. Cut the bead out of the tire on both sides.
3. Nail the tire to the board using the staples. (It may help to hold the staples with pliers.)

## Hay Bins

### Materials:

- 2 tractor tires
- 5 - 13 cm bolts with washers
- 2 - 5 cm thick plywood for the base
- 5 - 10 fence staples

### Equipment:

- Hammer
- Cutting knife or heavy shears
- Pliers

### Procedure:

1. Cut the plywood into the right size and shape for the tire. It should be 5 cm wider than the tire all the way around.
2. Cut the bead out of the tires on both sides.
3. Attach one tire to the board using the staples. (It may help to hold the staples with pliers.)
4. Bolt the two tires together.

## Hay Net

### Materials:

- 5 - 4 meter lengths of plastic binder twine
- 1 - 2.5 meter length of plastic binder twine
- 1 - metal ring (2.5 cm or larger)

### Equipment:

Scissors

### Procedure:

1. Tie left over binder twine together (single strand) or loop uncut twines together until you have 4 meters. Repeat five times.
2. Take the metal ring, fold a 4 meter length of twine in half. Slip the fold to the inside of the ring and pull a few cm through. Pull the ends through the loop. Repeat.
3. Split the twines.
4. Take a twine and tie it to the closest twine from the next set 12 cm from the ring. Repeat.

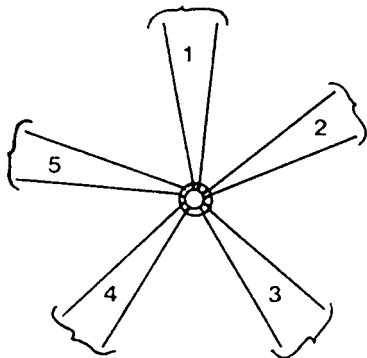
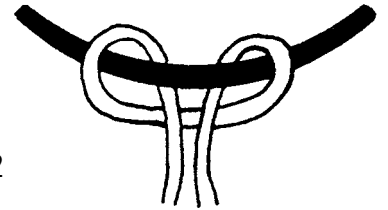

5. This is repeated to form the net. The next four sets of knots will be 15 cm apart. This will make the bag 1.12 meters long.

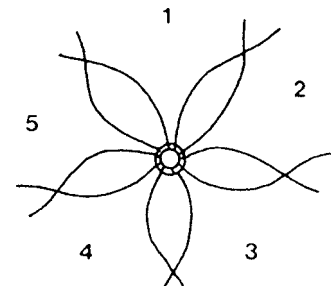

6. At the top, double the strands as they come out of the top. Tie the two strands in a knot 5 cm up. Fold the strands over and tie them securely to the last knot in the bag. Repeat.

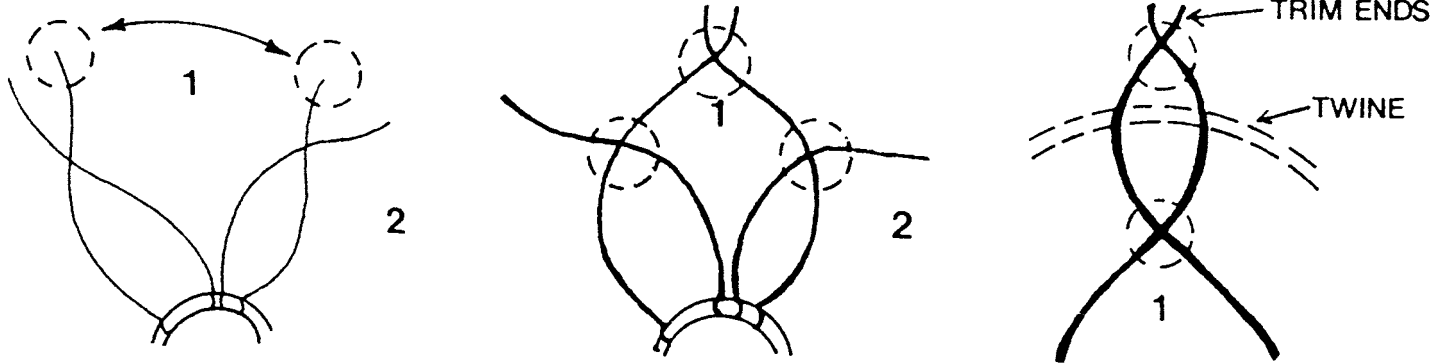

7. Trim the ends.
8. Run the length of the twine through the top loops. Tie the ends in a knot to form a circle. This is used to pull the bag closed.

---

## CLUB BANNER

---

Many 4-H clubs make their own banner. It can be displayed at club meetings and carried to identify the club at parades. Horse clubs may want to mount the banner on a pole so that two riders can carry it between them.

### Materials:

**Fabric** 1.9 meters (2 yards) of 115-centimeter (45 inch) wide fabric.

Just about any fabric will do, although if it is lightweight it may blow too much in the wind and/or too much light will shine through. Felt is easy because the edges do not have to be finished. If it will be used a great deal, it probably should be machine washable. Keep this in mind when choosing the fabric and also when deciding what decorations you will add.

**Thread** One spool of color to match fabric.

**Trims** Let your imagination run wild. Words and shapes are easy to do with felt or fabric appliqués, or outline with yarn or embroidery. Decorations can be added with ball fringe, tassels, rickrack, nail heads, rhinestones, ribbons, and so on.

### Equipment:

Basic supplies include:

- Yard or meter stick
- Piece of sharpened chalk or sharpened bar of white soap
- Pins
- Sewing machine.

*Depending on the types of trim used, other supplies may be needed:*

- Fusible web (for appliqués - in which case you also need an iron)
- Large - eye yarn needle (for yarn or embroidery thread)
- Hammer - for nail heads
- Fabric glue
- Hand sewing needle
- Chain with 6 mm (1/4" or 1/2") or 1.3 cm links (optional)

### Procedure:

1. On both edges of the banner turn the fabric to the wrong side 6 mm (1/4") and then 6 mm (1/4") again. Pin and stitch in place.
2. On the top edge, turn the fabric to the wrong side 6 mm (1/4") and then 7.5 cm (3"), pin in place, and stitch close to the inside fold. This makes a casing to slip a pole through to carry the banner.

3. On the bottom edge, turn the fabric to the wrong side 2.5 cm (1") and then 2.5 cm (1") again. Pin and stitch close to the inside fold. Into this wide hem you can choose to insert a length of chain; the extra weight will help prevent the banner from blowing in a breeze. Be sure to hand stitch both of the ends of chain in place.
4. Plan your banner on a piece of paper of the same size as the finished banner. If you have a piece of paper that is 28 cm (11") long [same as this page!], cut it 18 cm (7") wide; turn it sideways, and that is the shape of your banner.
5. Make a fairly accurate sketch of where things will go on the banner. Stand back and look at it to make sure letters are large enough to be read, the designs are centered and evenly spaced. If you use chalk to make the sketch, it is easy to brush them away. If you use soap, a damp sponge or steam iron will quickly remove it. Have a clear plan in mind before you start.
6. Choose colors for your designs that are in contrast to the background so they can be seen easily. If you are in doubt, cut out small shapes or letters and pin them to the banner. Have someone stand as far away as possible and tell you what the shapes are. If they cannot see what it is, you need to make a different color choice.
7. If you want to use yarn to make letters or outlines, it can be attached with fabric glue, fusible web, zigzag stitching on the sewing machine, or large hand stitching. It may take several strands of yarn to make the letters "fat" enough to read easily from a distance.
8. Appliqués can be attached by any of the methods mentioned above for yarn. If the fabric unravels easily, it would be a good idea to finish the edge with a zigzag machine stitch.

# HAY BAG

## Materials:

Lightweight canvas (2.4 m)

Heavy strong thread

30 cm of wide Velcro

## Equipment:

Tailors pencil

Yard or meter stick

Pins

Scissors

Sewing machine

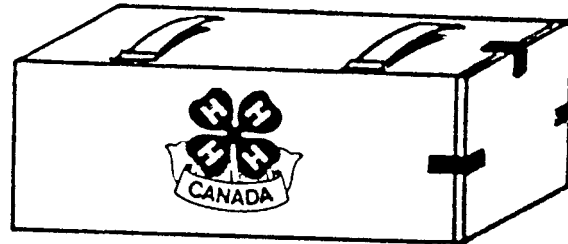

## Procedure:

1. Determine the size of bale you have. Add 13 cm to the length and width to allow for the seams and extra space for the bale.
2. Cut the fabric as follows:

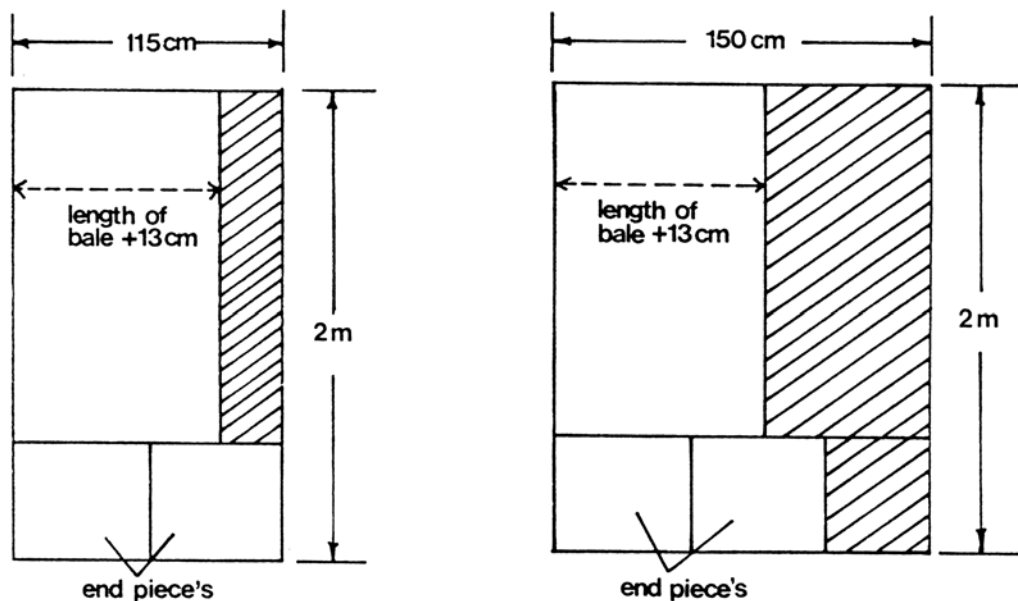

3. Pin edges together along the short ends of the fabric (wrong sides together).
4. Stitch 1.5 cm from the pinned edge to form a tube.
5. Pin the end piece into place, starting from one corner.

6. Turn the bag right side out.

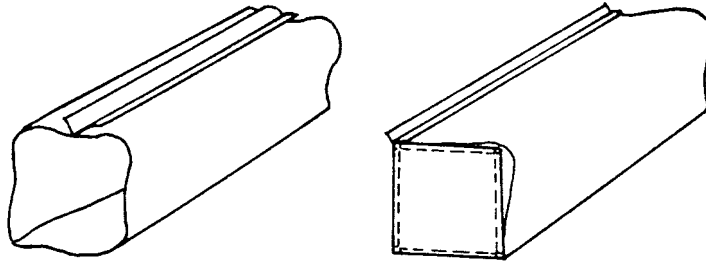

7. For handles, cut three pieces of fabric 19 cm x 8 cm.  
 8. Fold right sides together, pin lengthwise edges together and stitch 1.5 cm from the edge and across one end.  
 9. Turn the tube right side out.  
 10. Fold the raw edges to the inside of the tube (1.5 cm).  
 11. Repeat the second handle.  
 12. Stitch the handles on as follows:

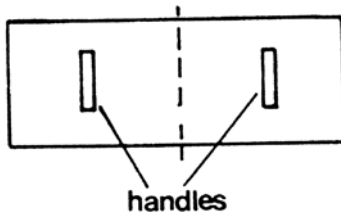
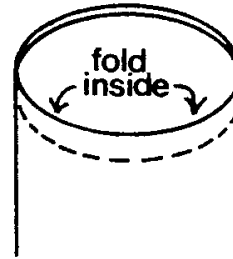
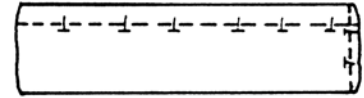

13. Turn under and machine stitch the second end piece.

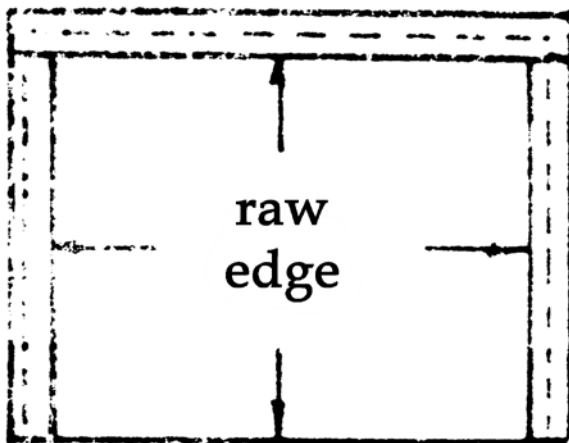

14. Cut the Velcro into 10 cm sections. Stitch fuzzy side down to the second end piece as follows.

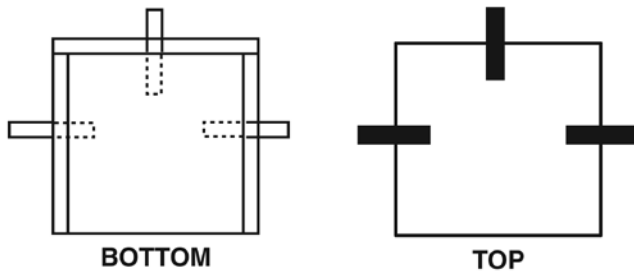

15. Attach the raw edge to the bottom side of the bag.

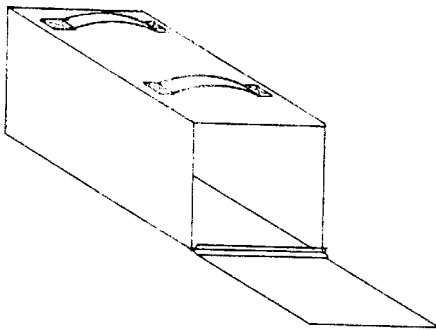

16. Mark on three sides of the bag, the position to attach the loop side or the Velcro.

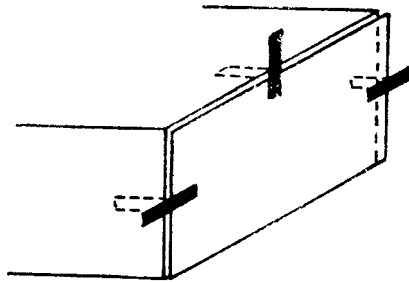

17. Sew on the Velcro. Bales vary in size, so directions will not include the size of the bag. The amount of fabric is an estimate. None of the loop side of the Velcro should go past the edge of the fabric.

18. The finished hay bag can be decorated with crests or attach your initials.

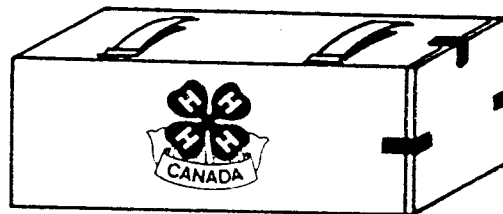

# SADDLE STAND

## Saddle Stand #1

### Materials:

2 – 2 X 15 X 55 cm (1" X 6" X 27")

2 – 2 X 30 X 85 cm (1" X 12" X 34")

Nails or screws

### Equipment:

Saw

Hammer

Screwdriver

Drill

Jigsaw

Pencil

Ruler or tape measure

Vise

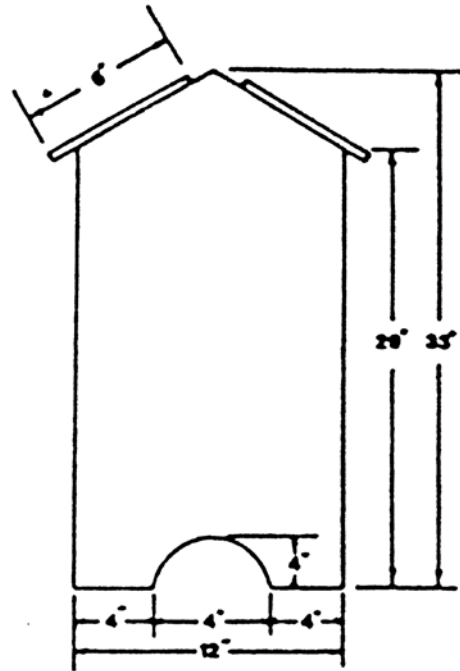

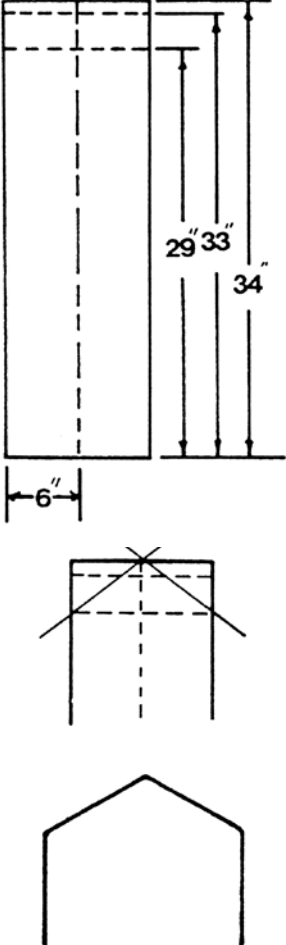
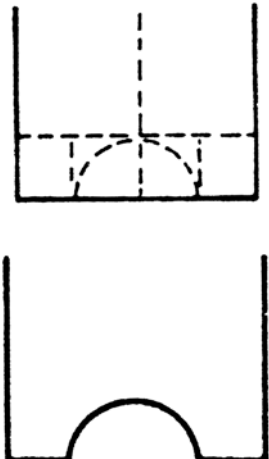
<b>Steps:</b>	<b>Method:</b>
<p>1. Cut top angle of the two side pieces 2 x 30 x 85 cm (1" x 12" x 34")</p> 	<ol style="list-style-type: none"> <li>Mark the center of the board lengthwise using the pencil and tape measure or ruler then draw dots on the board.</li> <li>Draw a light pencil line to connect the dots.</li> <li>Measure and mark at two or three points 82.5 cm (33") from one end of the board.</li> <li>Draw a line across the width of the board using two marks as a guide.</li> <li>Measure and mark two or three points 72.5 cm (29") from the bottom of the board.</li> <li>Draw a line across the width. This line will be 10 cm (4") below the first line across the width.</li> <li>Draw a line from the outside edge of the 72.5 cm (29") line to the 82.5 cm (33") line where it crosses.</li> <li>Cut across the last lines to give the angle.</li> <li>Do the same on the second board.</li> </ol>
<p>2. Cut the bottom curves on the end pieces.</p> 	<ol style="list-style-type: none"> <li>Use your lengthwise line to center this.</li> <li>Make several dots 4" from the bottom of the board.</li> <li>Draw a line through the dots.</li> <li>Mark a line 2" on either side of the centerline.</li> <li>Draw the lines.</li> <li>Use the lines as a guide to draw your curve.</li> <li>Cut the curve using a jigsaw.</li> <li>Follow the same steps as for the other end piece.</li> </ol>

3. Attach the top pieces.  
2 x 15 x 55 cm (1" x 6" x 27")

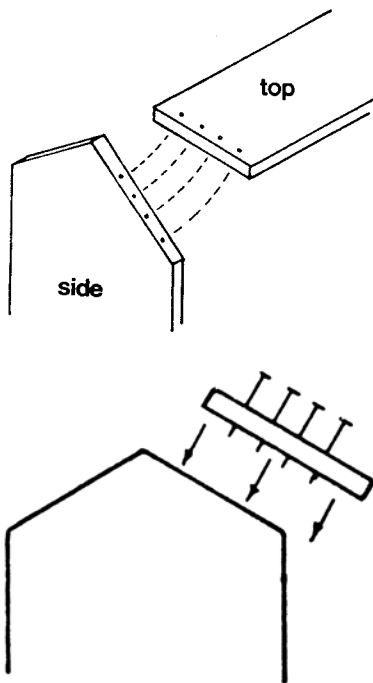

- Mark points at each end of the 2 X 15 X 55 cm (1" X 6" X 27") for 4 nails or screws to go through.
- Mark the angled edge of the side piece to match the markings on the boards for the top.
- Do the same for the other side piece using the other end of the board.
- If you are using screws, drill holes in through the marks on each 2 X 5 X 55 cm (1" X 6" X 27")
- Use a screwdriver to put the screws through the board and side piece.
- For nailing start them through the marks in the end pieces until that they show on the other side.
- Line up the marks on the side piece with the nails. Finish nailing.

4. Sand off pencil marks and rough spots.

## Saddle Stand #2

### Front

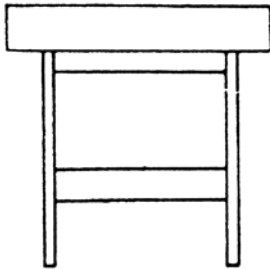

### Side

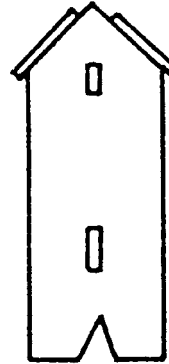

### Materials:

- 2 – 2 X 30 X 90 cm  
(1" X 12" X 36")
- 2 – 2 X 15 X 67.5 cm  
(1" X 6" X 27")
- 1 – 2 X 10 X 55 cm  
(1" X 4" X 22")
- 1 – 5 X 10 X 55 cm  
(2" X 4" X 22")
- Nails or screws

### Equipment:

- Saw
- Hammer
- Screwdriver
- Drill
- Pencil
- Ruler or tape measure
- Vice

**Steps:**

1. Cut the top angle of the two side pieces (1" x 12" x 36")

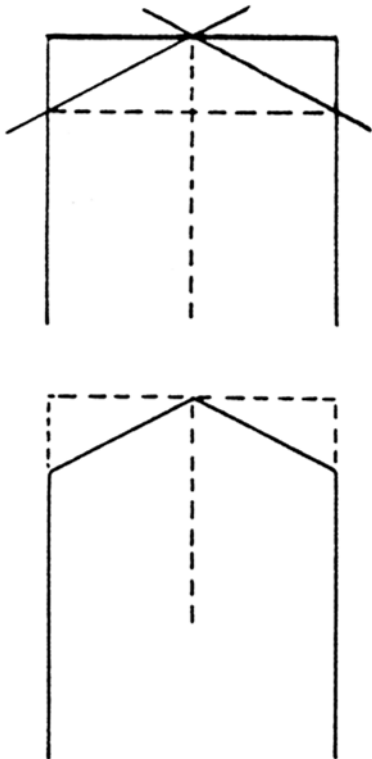
**Method:**

- Mark the center of the board lengthwise, by using the pencil and measuring tape or ruler to find the middle, then draw dots on the board.
- Draw a light pencil line to connect the dots.
- Measure and mark two or three points 4" from one end of the board.
- Draw the lines between the points across the width of the board.
- Draw a line from each outside edge of this line to the center line where it touches the edge of the board.
- Cut along these lines.

2. Cut the "V" out of the bottom end piece.

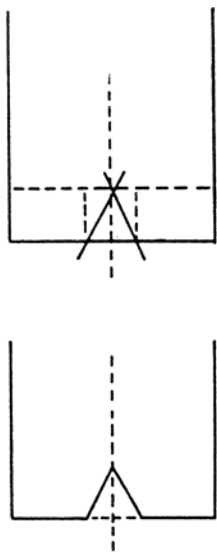

- Measure and mark 2 or 3 points 15 cm (6") from the other end of the board.
- Draw a line connecting the points.
- Using the ruler or tape measure mark points 5 cm (2") on either side of the centerline.
- Draw lengthwise connecting lines.
- Draw a "V" using these lines.
- Cut the V out using a handsaw or a jigsaw.

3. Attach the 3 X 10 X 55 cm (2" X 4" X 22") and the 2 X 10 X 55 cm (1" X 4" X 22") to the end pieces.

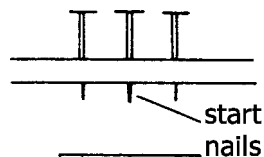
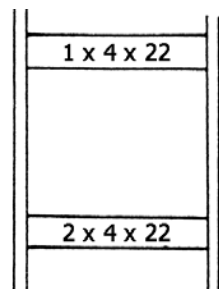
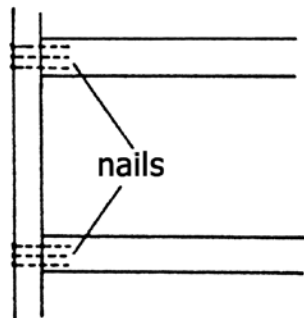
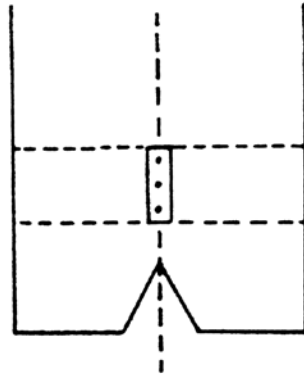
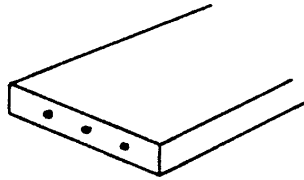

- a. Measure and mark for lines 20 cm (8") 30 cm (12") from the bottom of the end piece.
- b. Draw the two lines across the board.
- c. Mark lines 2 cm (1") on either side of the lengthwise dividing line.
- d. Draw in the lines.
- e. Mark points for 3 nails or screws 2 cm (1") apart.
- f. Mark the 5 X 10 X 55 cm (2" X 4" X 22") the same way.
- g. Drill 3 holes in each side piece (where you have marked).
- h. Line up the marks and attach the board with screws.
- i. Draw a line 10 cm (4") down from the line at the bottom of the top angle.
- j. Mark lines 1 cm (1/2") on either side of the center lengthwise line.
- k. Draw 2 lines.
- l. Same as e.
- m. Mark the points on the 2 x 10 x 55 cm (1" x 4" x 22").
- n. Same as g.
- o. If you are using nails start them through the marks in the end pieces so that they show on the other side.
- p. Line up with marks on the 5 x 10 x 55 cm (2" x 4" x 22") or 2 x 10 x 55 cm (1" x 4" x 22") and finish nailing.
- q. Nail the second board onto the end piece.
- r. Repeat steps n-p for the second end.

4. Attach the top pieces (1" X 6" X 30")

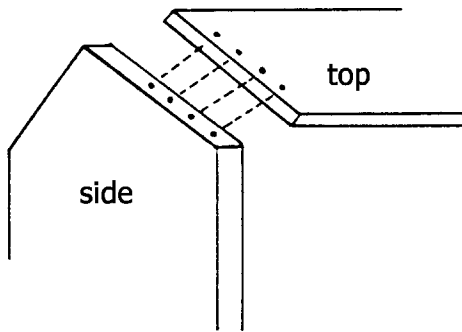

- Mark 7.5 cm (3") lines at both ends of the two boards.
- Draw connecting lines across the width of the board.
- Mark spots for 4 nails or screws.
- Mark the top angle of the end pieces to match.
- Follow the same procedure as 3f and 3g for screws, 3n - p.

5. Sand off pencil marks and rough spots.

### Saddle Stand #3

#### Materials:

25 feet (2 ½ joints) of ¾" EMT (Chrome colored tubing)

2 – ¼" X 3 ½" bolts and 4 nuts

4 – ¼" washers

13 – 3/16" pop rivets

80" of 1 ½" to 2 ½" nylon webbing

4 – 7/8" rubber crutch tips

#### Equipment:

Measuring tape

3/8" and 7/32", 13/64", or ¼" bit

Permanent markers

Small propane bottle

Pipe or tubing cutter

Spike and old knife that can be heated

Grinding wheel

Safety goggles

Tube bender

Square

Vise

Center punch (for making drill holes)

Drill

**Procedure:**

- Step 1** Take 3 joints of pipe – mark one 28" from one end, another 30" from one end and the other in the center (60") from the end with a line for cutting.
- Step 2** Cut on those 3 lines with a tubing cutter – you will now have the 5 pieces of pipe you will need for your project (28, 30, 92, 90 and 60 inches in length). The extra ½ of a pipe (60" piece) can be used for the next stand.
- Step 3** Mark the pieces of pipe as follows:
- 28" – with a dot 7¼" from each end and at the centre, 14".
- 30" – with a dot 8" from each end and at the centre, 15".
- 90" – with a dot 10" and 22 ½" from each end at the center, 45" and with a line that goes all the way around 27 ¾" from each end.
- 92" – with a dot 10" and 22 ½" from each end and at the center, 30" and with a line that goes all the way around 10 ¾" from each end.
- Step 4** Bend the 90, 92 and 60" pieces, using the following method:
- When using the tube bender, always work with the foot pedal towards the center of the pipe (so the bends end up in the right place).
- For each piece, place the indicator arrow of the bender on the bend line that you have marked, and bend the pipe to a 90° angle. Reset the bender on the other end and repeat the procedure. This creates both legs on the longer pieces.
- When bending the 60" piece, use the same method, but bend upwards to slightly past the 90° point. After both sides of this piece are bent, place the bender on the center piece, and with the handle of the bender on the ground, bend slightly to create a cradle for your saddle to sit on. (This reverse bend bows the legs back out a bit, that is why you bend them slightly past the 90° point).
- Step 5** To square the legs of the 3 bent pieces:
- Place a square alongside of each leg, and make sure that each leg is a true 90° by either bending it out further, or bringing it back in.
- Next, lay each piece on a level place on the concrete and square the legs the other direction by making sure all the legs lie flat on the concrete. If they don't, simply twist them gently until they do.

- Step 6** Using your original mark as a guide, remark the 3 bent pieces on the outside of the legs at the 3" mark (for the 60" piece) and the 22 ½" for the 92 and 90" pieces. \* If these 3 pieces are laid together on the concrete, the marks for the bolt holes should line up.
- Step 7** With a center punch, make a divet for the drill bit to rest in on those 6 marks.
- Step 8** Using a drill press (if you have one, or a hand drill if you don't) and a 3/8" bit, drill straight through the pipes from outside to inside. \*This makes the bolt holes to hold your stand together, so it is important to drill straight through from the outside of the U-shaped piece to the inside.
- Step 9** Flatten the ends of the 28" and 30" pieces (approximately 1 ½") using a vice. Make sure that both ends of the pipe are flattened in the same direction, as these pieces are the braces that have to sit flat against the sides of the stand's legs.
- Step 10** Using the grinder, smooth the rough ends of the braces and the legs, and take the sharp burrs off the bolt holes.
- Step 11** Remark your rivet holes, using your original marks as guides. Remark the 2 main pieces at 10" and at the center points (45 and 46"), on the side and the center of the 60" piece on the top of the pipe (lining up the marks as they lay on the floor together).
- Also remark the braces on sides – 28" at 7 ¼" from each end and 14" and a new mark 3/8" from each end. The 30" piece at 8" from each end and 15" and a new mark 3/8" from each end.
- Step 12** Use the center punch to divet the marks where you will drill holes for rivets (all of the pieces marked in Step 11).
- Step 13** Using a hand drill and a 7/32, 13/64 or ¼" bit, drill through only one side of the pipe where the divets are marked. Except the ends of the braces (3/8" from each end), where you drill through both thicknesses of the flattened tubing so that it can be attached to the legs.
- Step 14** Using a riveter, rivet the braces to the legs (28" brace to the inside set of legs, and 30" to the outside). \*Make sure to attach the braces to the outside of the legs, with the rivet holes to the inside.
- Step 15** Using a small propane torch to heat an old knife, cut and melt 4 pieces of webbing, each 20" long.

- Step 16** Using the same blow torch, heat a spike (held by vice grips) and melt a hole 1" from one end of each piece of webbing.
- Step 17** Through the burnt holes of the webbing, rivet the 3 pieces of webbing to one brace, and the 4<sup>th</sup> strap to the center hole (with the tails of the webbing hanging down).
- Step 18** Line up the stand and insert the bolts from the outside of the stand to the inside. \*Make sure the 2 sets of legs have the braces on the outside, with the rivet holes of the braces facing each other. Use washers to protect the drilled holes from wear. Put the nuts snugly on the bolts and use a 2<sup>nd</sup> nut (tightened to the 1<sup>st</sup> with wrenches) to make sure that the nuts do not become loose and shake off.
- Step 19** Open the stand until there is a 10" to 10 ½ " spread (inside measurement) between the 2 outside supports (the spread of a saddle). Tie a strap of some sort across to hold this measurement steady.
- Stretch the 3 webbing straps across from one brace to the other and mark where to burn the holes (over the top of the brace, a ¾ wrap and up to the empty hole). Stretch the top webbing across the center bar (making sure it is straight up and down) and mark where to put the center hole. Continue the strap across and over the other supporting leg with a ¾ wrap and up to mark the 3<sup>rd</sup> hole of the top strap. Then, using the heated spike, burn these holes and rivet in place.
- Step 20** Put the rubber crutch tips on the ends of the 4 legs, using a hammer to tap them on if they are tight. \*The height of these can be adjusted slightly so that the stand sits squarely if your legs happen to be a little uneven.
- Step 21** Tap the edges of the rivets down with a hammer, so that they follow the rounded contour of the pipe. (They will be less likely to rub against and wear the webbing.)

# SADDLE PADS

## Western Saddle Pad #1

### Choosing the Size:

These directions are for either a 76 x 92 cm (30 x 36") or a 102 x 102 cm (40 x 40" pad). The larger pad is suggested for a large stock seat saddle. If you are in doubt, lay an old bed sheet or other flat piece of fabric over the horse. Place the saddle in the proper position. Draw a line around the saddle with a soft pencil. Remove the fabric from the horse and measure the length and width of the outline. The pad should be about 20 cm (8") longer and wider than the outline of the saddle.

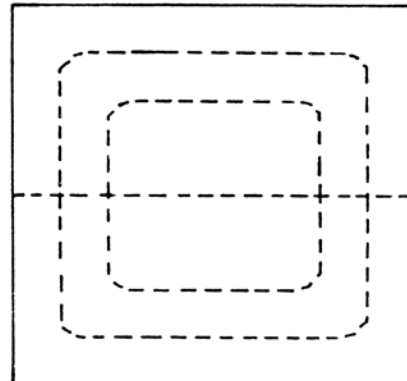

### Materials:

#### Fabric

**Type** Choose a soft, thick, fuzzy fabric that will cushion the saddle on your horse's back. Some possibilities include wide wale corduroy, fleece, pile fabric, or an old bed blanket. Whatever you choose must be machine washable. Wash the fabric before sewing. Choose a natural fiber fabric (cotton or felt pad) to be placed between your horse's back and the saddle pad.

**Amount** The following chart will tell you how much to buy, depending on the width of the fabric you choose:

	Size of Pad:	92 cm wide	115 cm wide	150 cm wide
Small	76 x 92 cm	1.5 meter (1 3/4 yard)	1.5 meter (1 3/4 yard)	1 meter (1 yard)
Large	102 x 102 cm	not possible	2 m (2 1/4 yard)	2 m, but a considerable amount will be wasted; you can use the scraps for tack covers and other small items.

**Thread** 1 spool of color to match fabric.

### Equipment:

Pencil                      Yard or meter stick  
 Scissors                    Straight pins  
 Sewing machine        Masking tape

**Procedure:**

1. If necessary, trim the fabric to the right size. Look at these drawings to see how much to trim for your particular pad size and fabric.

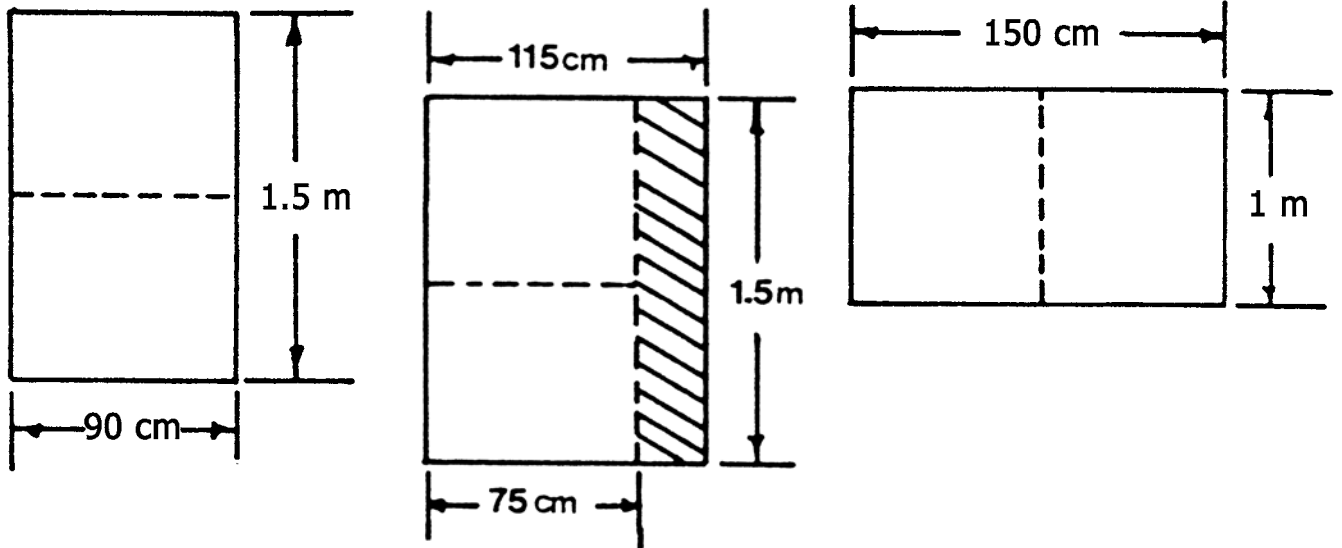
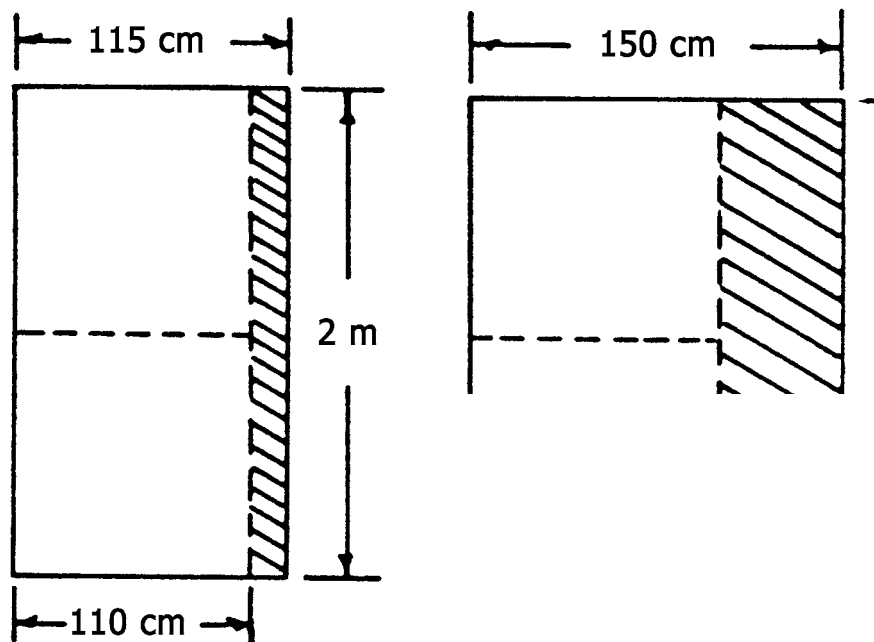
**Small****Large**

- Fold the fabric in half with the short ends matching. Pin the edges together.

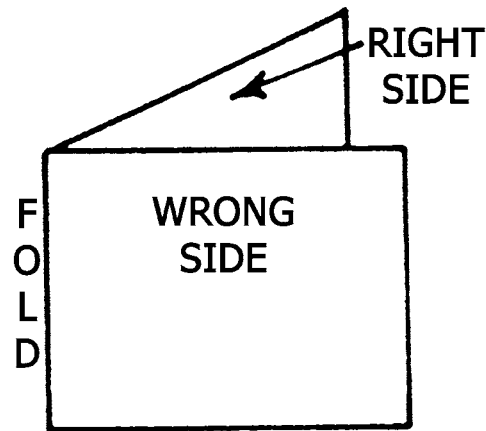

- Starting at one folded corner, stitch 1.5 cm (5/8") from the cut edges along one side, turn the corner, and stop part way across the second side. Be sure to back stitch at both ends of this row of stitching.
- Leave about a 38 cm (15") opening along the second side. Then complete the stitching along the second and third sides, sewing 1.5 cm (5/8") from the cut edges and backstitching at both ends.

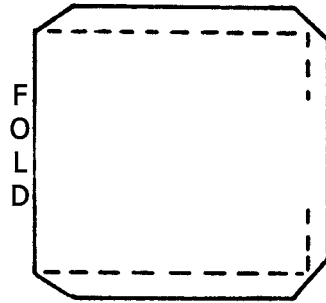

- Trim the corners, cutting close to, but not through the line of stitching.
- Turn the pad right side out through the opening left on the side opposite the fold. With your fingers and/or the eraser end of a pencil, push out the corners to make sure they are square.
- In the space where the opening was left, turn the cut edges of the fabric to the inside 1.5 cm (5/8"). Match and pin the two folded edges of the opening together.
- On the sewing machine, stitch along the pinned area about 6 mm (1/4") from the folded edges. Be sure to backstitch at the beginning and end of the seam.
- Topstitch around blanket, 10 cm (4") from the edge. To do this, put a piece of masking tape 10 cm (4") to the right of the sewing machine needle on the bed of the machine. Use the tape as a guide and stitch around all four sides of the pad, 10 cm (4") from the edge. Make sure you stop 10 cm (4") from the end when you come to a corner. You may want to mark the corners ahead of time with pins.

## Western Saddle Pad #2

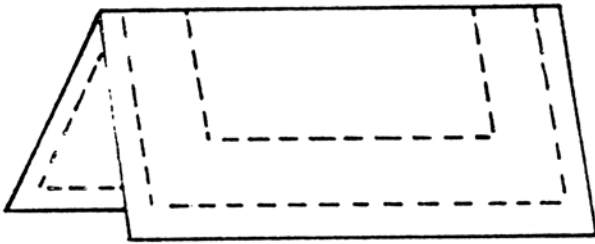

Quilted western saddle pad 69 x 78 cm. This is a common size of saddle pad in the tack shops.

### Materials:

**Foam:** The thickness you choose will depend on the thickness of saddle pad you want for your horse. A horse with a sensitive back will be more comfortable with a heavier pad. When purchasing foam, use the 2 or 5 cm thickness, 69 x 78 cm.

**Fabric:** Use a heavy washable material. Corduroy, fleece, pile and blanket material all work well. When buying the material consider how often you will be washing the pad. A long or thick pile will take much longer to dry.

Amount:	width	length
	92 cm	1.5 m
	115 cm	1.5 m
	150 cm	1.0 m

**Thread:** 1 spool 450 cotton thread that matches the material.

### Equipment:

Tailoring pencil or chalk

Yard or meter stick

Scissors

Straight pins

Needles

Sewing machine

Masking tape

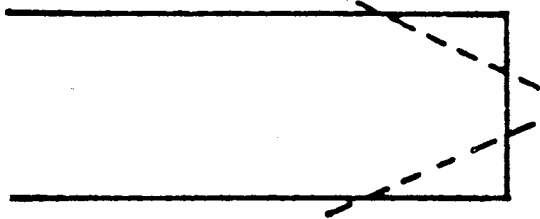
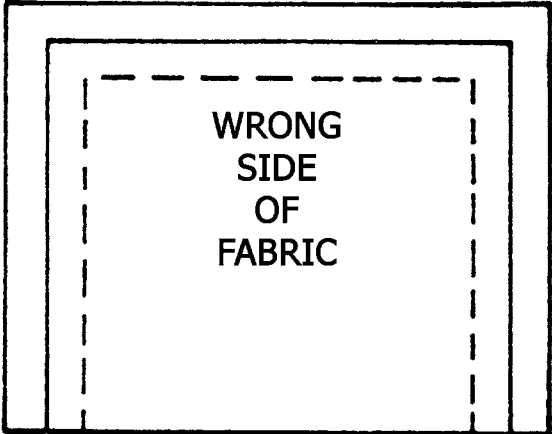
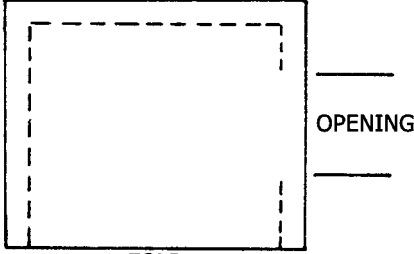
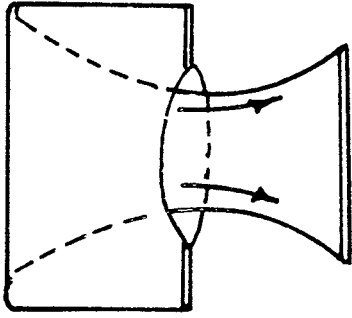
Steps	Method
<p>1. Cut and shape the foam.</p> 	<p>a. Cut the foam to the desired size using scissors.</p> <p>b. Trim the edges as in the diagram.</p>
<p>2. Measure fabric for the saddle pad.</p>  <p style="text-align: center;">FOLD</p>	<p>a. Fold the fabric, in half lengthwise (150 cm) or crosswise (92 and 115 cm), right sides together.</p> <p>b. Pin the edges of the fabric together.</p> <p>c. Using the tailoring chalk and a ruler, outline the starting size of your foam.</p> <p>d. Add one half the thickness of your foam to this by drawing a second line around your original mark. (2.5 cm on each side if the foam is 5 cm thick) This will be your stitch line.</p>
<p>3. Stitch around the saddle pad on the outside chalk line. Leave a 25 – 30 cm open on one side.</p>	 <p style="text-align: center;">FOLD</p>
<p>4. Trim edges to 1.5 cm. Zigzag raw edges except along the open edge.</p>	
<p>5. Turn the cover right side out by pulling it through the opening.</p>	

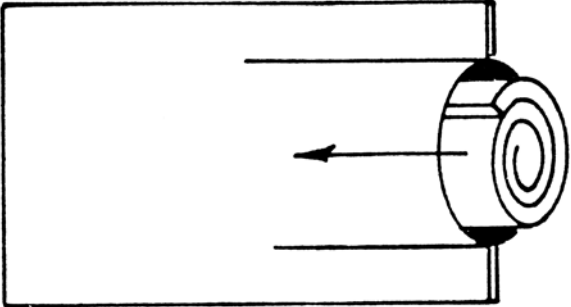
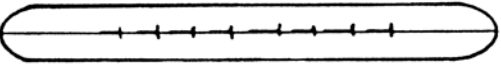
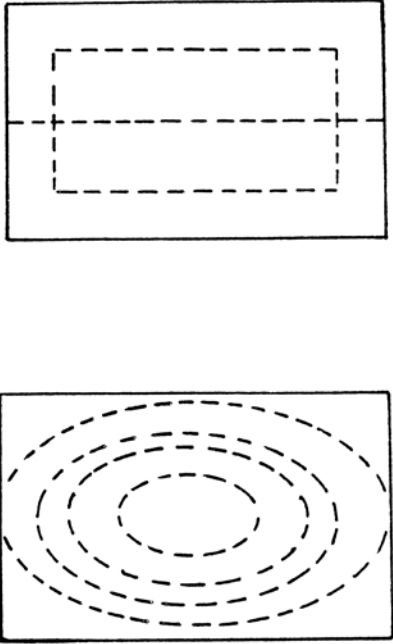
<p>6. Roll the piece of foam into a tube and push it through the opening. Unroll when it is inside. Center the foam inside the cover.</p>	
<p>7. Pin the raw edges inside the cover. 8. Hand stitch the opening to close it.</p>	
<p>9. The saddle pad is quilted to keep the foam and fabric from folding or rolling up. If your fabric and foam are thin, this may be done on the sewing machine. On thick fabrics this may be done with hand stitching.</p>	

# TACK COVERS

Tack covers will protect the sensitive areas on a horse at any time, and give extra protection when the horse is being shipped. They are quite fast to make and are a simple beginning project.

## Halter Cover

### Materials:

**Fabric:** Any soft, thick pile fabric, such as wide - wale corduroy or fake fur with a knit backing, are good choices. Make sure it is machine washable. One meter (or 1 yard) is enough for several covers.

**Thread:** 1 spool to match fabric.

### Velcro

### Supplies:

Measuring tape  
Soft pencil or felt tip pen  
Scissors  
Straight pins  
Sewing machine

### Procedure:

1. Measure the length of the area to be covered - for example the noseband, crown piece, or cheek piece. Record the length here:  
\_\_\_\_\_ cm / inches. (circle unit of measurement)
2. Measure around the halter in the area to be covered. This amount will take into account the width and thickness of the leather. To this amount add 2.5 cm (1") to allow for overlap on the cover. The total amount of the width of the cover is:  
\_\_\_\_\_ cm / inches. (circle unit of measurement)
3. Place the pile fabric on the table, wrong side up. Mark the dimensions you recorded in steps 1 and 2 on the back of the fabric with the pencil or pen. Cut out accurately.
4. To finish the edges of the fabric, stitch around all four sides with a zigzag machine stitch. Or use a straight stitch 6 m (1/4") from the edge and again 1.3 cm (1/2") from the edge.
5. Cut matching strips of Velcro (one loop and one hook strip) the same length as the edges of the cover. Or you can cut several shorter patches and space them out along

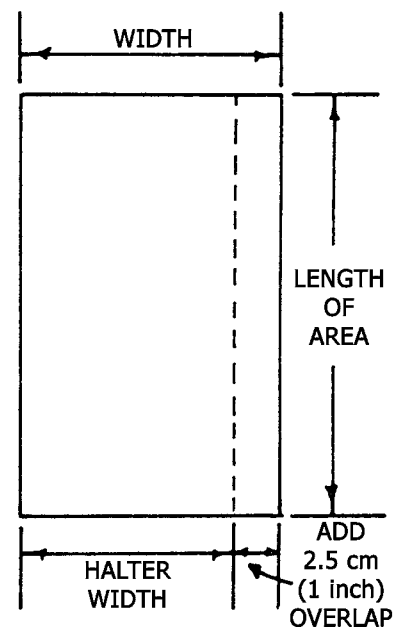
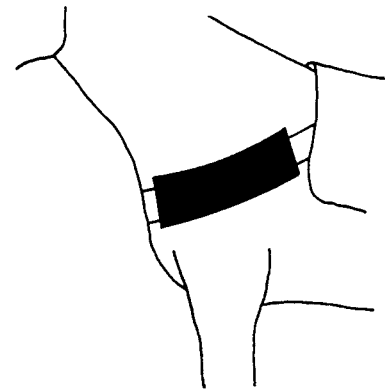

the long edges.

- Using the loop half of the Velcro, put it loop-side-out on the wrong side of one long edge of the cover. Pin in place. Stitch around twice, close to the edge.
- Using the hook half put it hook-side-out on the right side of the opposite long edge. Pin in place. Stitch around twice, close to the edge.

## **Additional Tack Covers**

### **Materials:**

The same as for halter covers, but you do not need Velcro.

### **Supplies:**

The same as for halter covers.

### **Procedure:**

- Measure the length of the piece to be covered - plate, collar, or girth. Record the length here: \_\_\_\_\_ cm / inches. (circle unit of measurement)
- Measure around the area to be covered, taking into account the width and thickness of the leather. To this amount add 5 cm (2") to allow for seams and some room for putting the cover on. The total amount for the width is: \_\_\_\_\_ cm / inches. (circle unit of measurement)
- Place the pile fabric on the table, wrong side up. Mark the dimensions you recorded in steps 1 and 2 on the back of the fabric with the pencil or pen. Cut out accurately.
- Finish the two short edges of the cover by stitching across with a zigzag machine stitch. Or use a straight stitch 6 mm (1/4") from the edge and again 1.3 cm (1/2") from the edge.
- With the right sides of the fabric together, match the two long edges and pin in place.
- Stitch together 1.3 cm (1/2") from the edge, backstitching at the beginning and end.
- Turn right side out and slip onto the breast collar or girth.

# COOLING SHEET

## Materials:

**Fabric:** 4.4 meters (4 3/4 yards) of 115 cm (45") wide, machine washable fabric. Denim is a good choice because it is sturdy. You might also choose kettle cloth, sailcloth or corduroy. This makes a cooler for a 15.2 horse; for a smaller horse or pony less fabric is necessary.

**Thread:** 1 spool of matching color.

**Twill or double fold bias tape:** 1 package

**Velcro:** 15 cm (6").

## Supplies:

Straight pins

Scissors

Pencil or chalk

Meter or yard stick

Sewing machine

Iron and ironing board

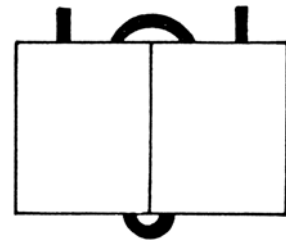
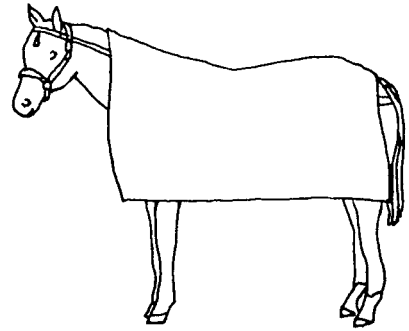

## Preparation of Fabric:

1. Wash the fabric with detergent to remove any excess fabric finish.
2. Straighten ends of fabric by tearing across, or pulling a crosswise thread and cutting on the line formed.
3. Lay the fabric flat on a table. Measure the length of the fabric and mark the halfway point with a pin. Do this to both edges of the fabric and in the middle. Using a meter or yardstick, join the points marked with a pencil or chalk line; cut across on this line. There will be two pieces, each one approximately 115 x 200 cm (45 x 79").

**Procedure:**

1. Match pieces with right sides together. Pin the two layers together along one of the selvages (finished) edges. Stitch together, 1.3 cm (1/2") from the edge. Press the seam open.
2. To hem, stitch around all four sides of the cooler, 1 cm (3/8") from the edge. Turn the fabric to the wrong side along the stitching line. Fold over another 1 cm (3/8"). Pin folds in place and stitch round, close to the first fold and through all three thicknesses.
3. Place the cooler on your horse with the center seam running along its back. With pencil or chalk, mark the sheet where it touches the outside edge of the horse's ears and where it touches both sides of the tail. Also mark where the sheet crosses the middle of the horse's chest. This is where you will put the Velcro to hold the cooler in place.
4. Leave the cooler on your horse. Use a strip of twill or double-fold bias tape to form a loop over the horse's ears and attach to the cooler at the places marked. Pin in place. Use another tape to go under its tail and attach to the cooler. Adjust to make sure the strips are snug enough to hold the cooler in place, but loose enough to be comfortable.
5. Remove the cooler from your horse. With the tape ends on the wrong side of the fabric, stitch securely in place.
6. Attach the Velcro to the places marked along the front edge where the cooler rests on your horse's chest. On the wrong side of fabric, place the loop side of the Velcro wrong side up at one placement mark. Overlap on fabric 2.5 cm (1"). Pin and stitch securely in place.
7. Place the hook side of the Velcro on the other placement mark, right side up. Overlap on fabric 2.5 cm (1"). Pin and stitch securely.
8. Your cooler is done. You can add braid or decorative trim along the edge, adding a decorative appliqué, or embroidering your horse's name.

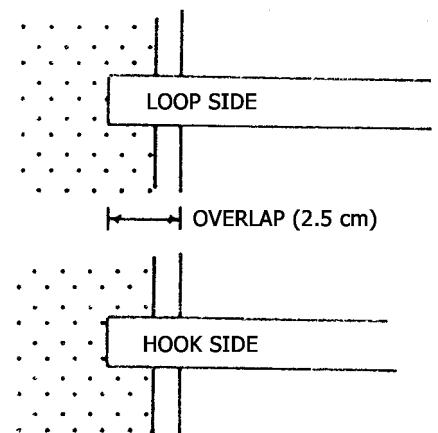
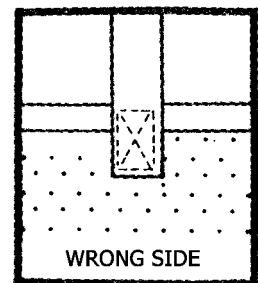
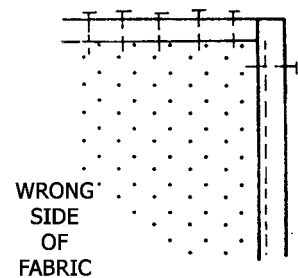
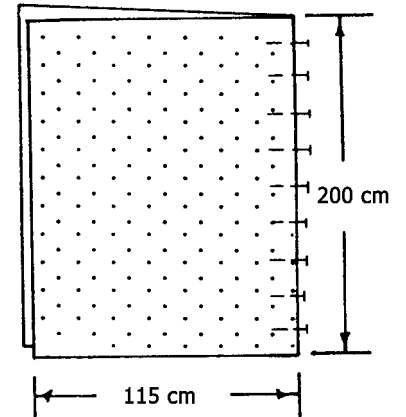

# LEG WRAPS

## Leg Wrap #1

### Materials:

**Fabric:** Vinyl with quilted backing, or vinyl and 1 - 2 cm thick foam

**Foam:** 115 cm width - 1.6 meters

150 cm width - 0.45 meters

**Thread:** 1 spool of matching polyester/cotton thread

**2.5 cm Velcro:** 150 cm (60")

### Equipment:

Pins

Scissors

Pencil or chalk

Meter or yard stick

Tape measure

### Procedure:

1. Cut the fabric into pieces for the leg wraps.

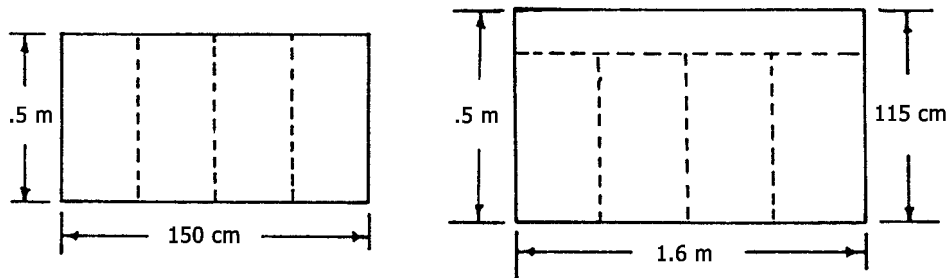

2. If foam is used for backing, follow the same cutting directions.
3. Pin the foam to the vinyl, stitch. You may do some quilting.

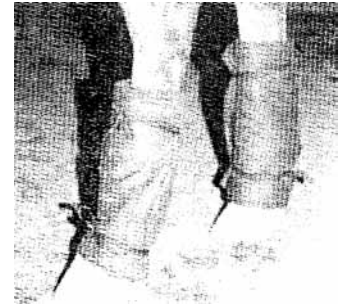
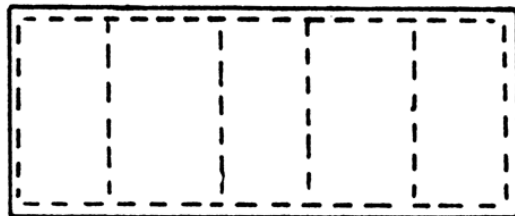

4. Place the fabric right side up on a table with the long edge facing you. Use three strips of the hook side of Velcro. Put one strip, right side up, 2.5 cm (1") down from the upper right-hand corner. (See diagram below). Pin the end in place. Put the second strip 2.5 cm (1") up from the lower right-hand corner; pin in place. Center the third strip between the first two; pin. Stitch the pinned ends twice, 1 cm (3/8 ") from the edge.

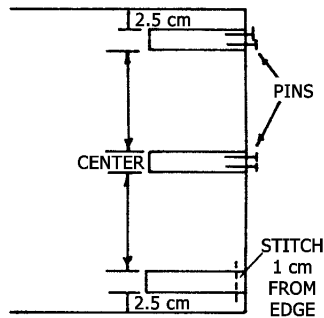

5. Place three strips of the loop side of Velcro right side up as shown in the diagram, using the marks you have just made. Center the first piece parallel to the long edge of the fabric. Place the last two strips 2.5 cm (1") from the long edges. (See diagram.) These three pieces should line up with the first Velcro strips you attached. Pin around all four edges and stitch around each piece twice, or zigzag.

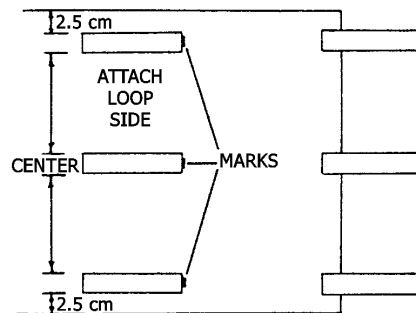

## Leg Wrap #2

### Materials:

#### Fabric

#### Type:

Beginning sewers will find it easiest to work on denim, poplin, or cotton twill. More experienced sewers may choose fake fur since it makes soft, fuzzy leg wraps. Cotton/polyester knit is similar to commercially made wraps. But whatever type of fabric you choose, be sure it is machine-washable.

#### Amount:

If the fabric you choose is 115 cm (45") wide, you will need to buy 1.6 meters (1 3/4 yards). If the fabric is 1.5 meters (60") wide, you will need 90 centimeters (1 yard).

**Thread:** 1 spool polyester/cotton of matching color

**1.5 cm Velcro:** 150 cm (60")

**Foam:** Buy enough 1.3 cm (1/2") thick foam to make four pieces, each one 35 x 43 cm (14 x 17"). One way to buy foam is from mail order catalogues, where it is available by the foot in standard widths. You waste the least by buying 76 cm (2 1/2 feet) of 90 cm (36") wide foam.

### Supplies:

Straight pins

Safety pins (for fake fur)

Hand sewing needle

Sewing machine

Measuring tape or ruler

Scissors

Pencil or chalk

Paper clips

### Preparation:

1. Cut fabric into four equal strips, each one 90 cm (36") long and 38 cm (15") wide.

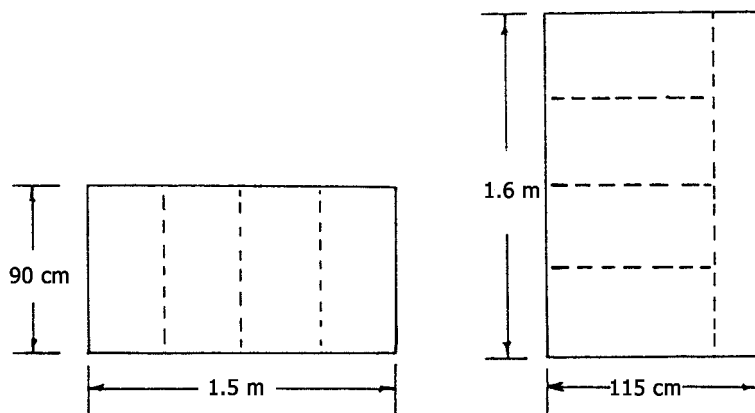

2. Cut the Velcro into twelve 12.5 cm (5") lengths.
3. Round off the four corners on each piece of foam. First draw a cutting line by placing a quarter or large spool of thread on the corner of the foam and tracing the curve with a pencil or piece of chalk; trim along that line.

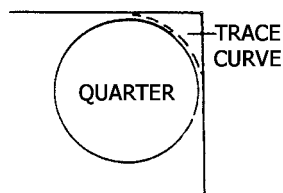

**Procedure:**

1. Place the fabric right side up on a table with the long edge facing you. Use three strips of the hook side of Velcro. Put one strip, right side up, 2.5 cm (1"). Pin the end in place. Put the second strip 2.5 cm (1") up from the lower right-hand corner; pin in place. Center the third strip between the first two; pin. Stitch the pinned ends twice, 1 cm (3/8") from the edge.

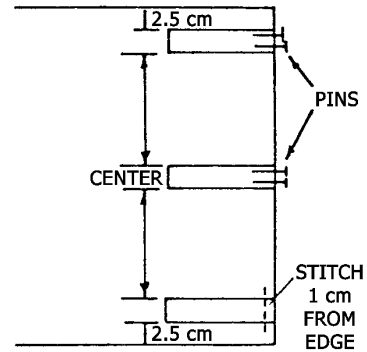

2. Fold the leg wrap in half, wrong sides together. Put paper clips around the open edges to hold them together. The Velcro strips should be turned out, forming three "tails". Wind the leg wrap around your horse's leg. With a pencil, chalk, or safety pins (for fake fur), mark where the ends of the Velcro tails come on the wrap.

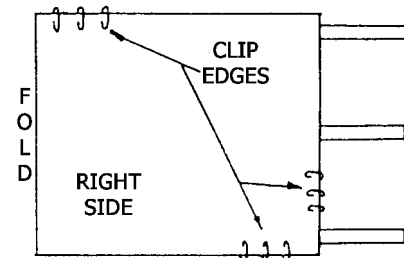

3. Unpin and unfold the leg wrap. Place three strips of the loop side of Velcro right side up as shown in the diagram, using the marks you have just made. Center the first piece parallel to the long edge of the fabric. Place the last two strips 2.5 cm (1") from the long edges. These three pieces should line up with the first Velcro strips. Pin around all four edges and stitch around each piece twice.

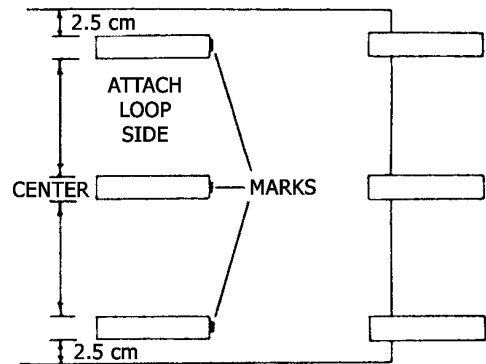

4. Fold the leg wrap in half again, with right sides together and the Velcro strips to the inside. Pin around the three open edges. Stitch around twice, 1.3 cm (1/2") from the edge and ending 20.5 cm (8") from the fold.

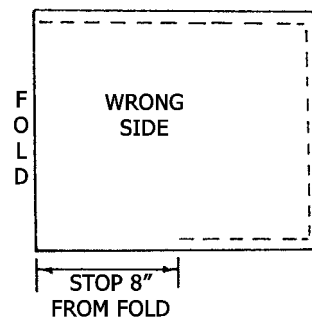

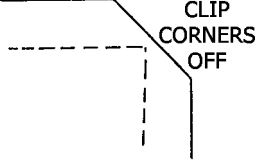
5. Trim corners as shown.	
6. Turn right side out. Insert one piece of foam and adjust until it is flat and smooth. Turn the open edge 1.3 cm (1/2") to the inside and then stitch closed by hand. Finish the three remaining leg wraps the same way.	

# TAIL GUARD

## Materials:

- 0.4 m quilted cotton or
- 0.4 m fiberfill and 0.8 m fabric
- 1 m cotton tape
- 2 m bias edging tape

## Equipment:

- Scissors
- Pins
- Thread
- Needles or a sewing machine

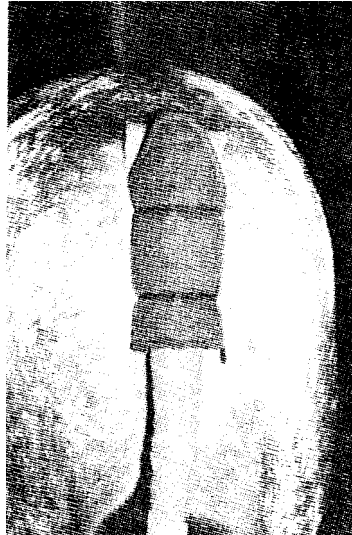



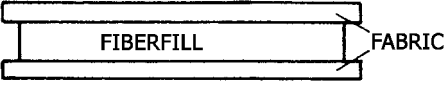
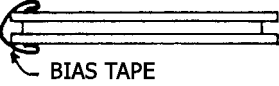
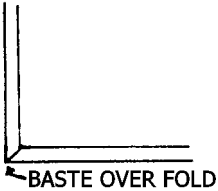



Steps	Method:
<p>1. Make a pattern.</p>	<p>Draw a pattern sample on tissue paper or brown paper.</p>
<p>2. Cut out your fabric. If your fabric is not quilted, cut two pieces. If you are using quilted fabric that does not have a firm backing cut a piece of plain fabric from the pattern.</p>	<ol style="list-style-type: none"> <li>a. Set the pattern on the fabric with the straight edge of the side an even distance from the selvage.</li> <li>b. Pin the pattern to the fabric.</li> </ol>

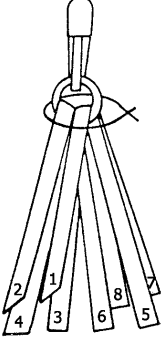

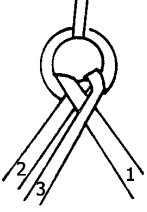
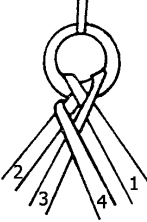
<p>3. Sew the pieces together so that there is fiberfill between two layers of fabric.</p>	<p>a. Pin your pieces together so that they are as follows;</p>  <p>b. Hand or machine baste 3 - 5 mm (1/8 - 1/4 inch) from the edge all of the way around.</p>
<p>4. Sew the bias tape around the edge of the tail guard.</p>	<p>a. Fold the bias tape around the edge of the guard, so that the raw edge is enclosed. Pin.</p>  <p>b. Hand baste the tape. Fold the corners as follows. Remember, there is a top and bottom side. Machine baste through the fold.</p>  <p>c. Machine stitch around the edge of the bias tape.</p>
<p>5. Sew on the ties.</p>	<p>a. Cut the tape into three equal lengths.</p> <p>b. Place the cotton tape on the tail guard following the pattern in step 1b.</p> <p>c. Pin each piece of tape onto the top of the tail guard.</p> <p>d. Stitch a 7.5 cm (4") length, the tape on to the tail guard so that ends of even length hang on each side. The tapes are spaced 5 cm (2") apart vertically.</p>

# BRAIDING REINS

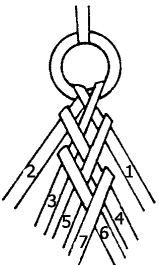
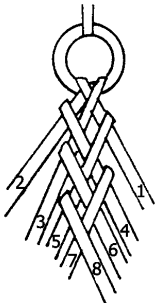
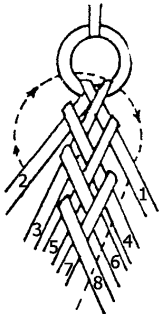

## Round Braiding, Split Reins

<p>Corner and arrange the rawhide, leather, or cord through the snap as shown, with one half the length on each side. If rawhide or leather is used, the rough side should face the center of the pile. Secure this with a piece of wire below the snap. Tighten. Divide the bundle in two. Hang this on a nail on a wall.</p>	
<p>To start the braid cross the top left (#1) strand over the top right strand (#2).</p>	
<p>Continue working with the strands numbered as in Figure 1. Cross the second string on the right (#3) over strand.</p>	
<p>Cross the second string on the left (#4) over strand #3.</p>	
<p>Cross strand #5 over strand #4.</p>	

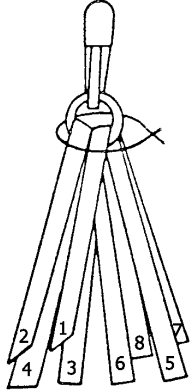

<p>Cross strand #6 over strand #5.</p>	
<p>Cross strand #7 over strand #6.</p>	
<p>Cover strand #8 over strand #7.</p>	
<p>Continue the braid with four more strands (Strands 1 - 4 braided again) by reaching behind the braid. Pull strand #2 behind the braid to the right side. Weave it under strands #1 and #4 and over strands #6 and #8.</p>	
<p>If you have a core for your bosal, put it into the center of the braid. Continue to braid.</p>	

<p>Pull strand #1 behind the braid to the left side. Weave it under strands #3 and #5 and over strands #7 and #2.</p>	
<p>If more than 8 strands are used you change your weaving pattern. For 12 strands it will be over 2, under 2, over 2. With 16 strands it will be under 2, over 2, under 2, over 2.</p>	
<p>Braid 3 meters (10 feet), when this is done, tighten a piece of strong wire around the end of the braid. This keeps the braid from coming loose.</p> <p>Weave the last 5 cm of the braid.</p> <p>Dampen the braid then roll it between two boards to make it round.</p>	

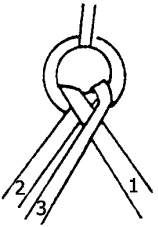
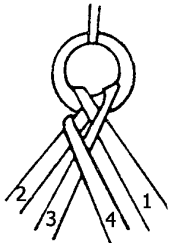
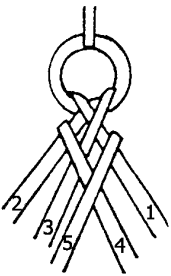

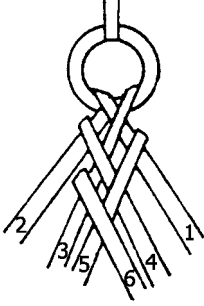
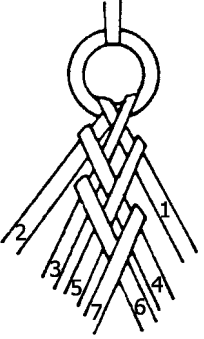
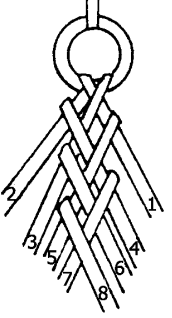
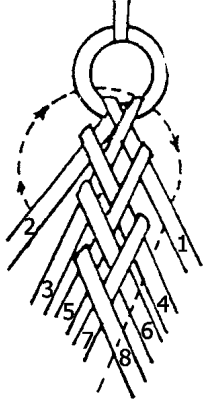
## Round Braiding, Rommel Reins

<p>Center and arrange the rawhide, leather, or cord through the snap as shown in Figure 1, with one half the length on each side. If rawhide or leather is used, the rough side should face the center of the pile. Secure this with a piece of wire below the snap. Tighten. Divide the bundle in two. Hang this on a nail on a wall.</p>	
<p>To start the braid, cross the top left strand (#1) over the top right strand (#2).</p>	
<p>Continue working with the strands numbered as in Figure 1 - Cross the second string on the right (#3) over strand #1.</p>	
<p>Cross the second string on the left (#4) over strand #3.</p>	
<p>Cross strand #5 over strand #4.</p>	

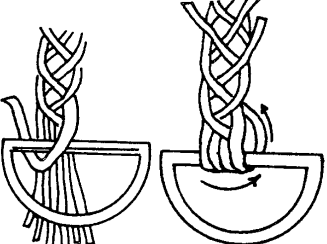
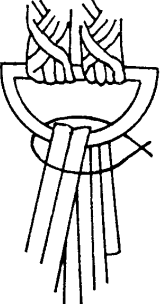

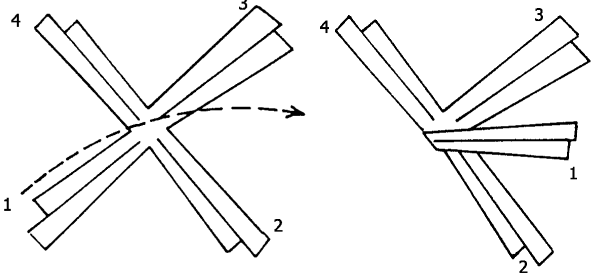
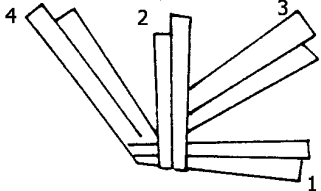
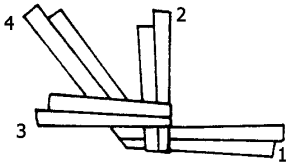
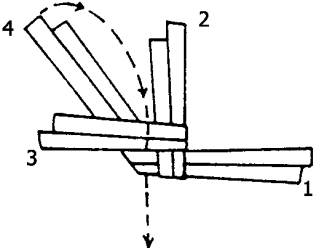
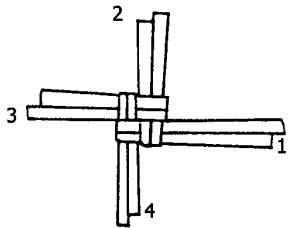
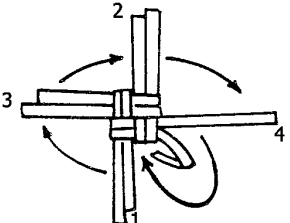
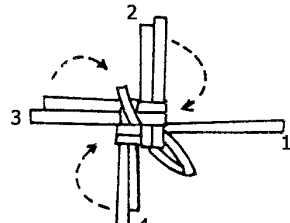
<p>Cross strand #6 over strand #5.</p>	
<p>Cross strand #7 over strand #6.</p>	
<p>Cover strand #8 over strand #7.</p>	
<p>Continue the braid with four more strands (Strands 1 - 4 braided again) by reaching behind the braid. Pull strand #2 behind the braid to the right side. Weave it under strands #1 and #4 and over strands #6 and #8.</p>	

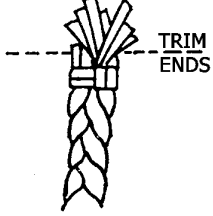

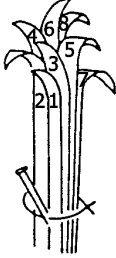

<p>If you have a core for your reins, put it into the center of the braid and continue to braid.</p>	
<p>Pull strand #1 behind the braid to the left side. Weave it under strands #3 and #5 and over strands #7 and #2.</p>	
<p>If more than 8 strands are used you change your weaving pattern. For 12 strands, it will be over 2, under 2, over 2. With 16 strands it will be under 2, over 2, under 2, over 2.</p>	
<p>Braid 1.3 meters (4 feet). This will be braided onto a 2.5 cm (1") ring or D-ring. Wrap wire around the braid 7.5 cm (3") from the end. This keeps the braid from coming loose.</p>	
<p>Each end will be folded around the ring and braided back into the braid. Each strand will be pulled to the outside and cut at different lengths. Braid another rein, following the same directions.</p>	
<p><b>Third Section of the Romel</b></p>	
<p>This is done the same way as the two reins, but is started from the ring. Braid 1.3 meters (4 feet). Wrap a wire around the end to hold the braid. Separate the strands into four sections.</p>	

<p>Fold section #1 to the right, between sections #2 and #3.</p>	
<p>Fold section #2 up over section #1. It will be between #3 and #4.</p>	
<p>Fold section #3 to the left over section #2 and #4.</p>	
<p>Fold section #4 down over section #3 under section #1.</p>	
<p>Complete knot.</p>	
<p>Take one strand and pull it counter-clockwise past the section to its left.</p>	
<p>Pull it up through the center of the knot.</p>	

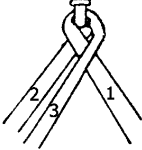
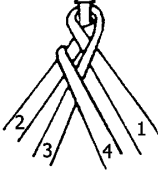
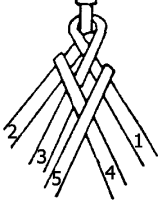
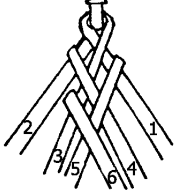
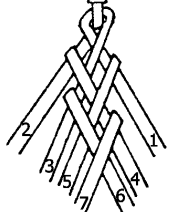
<p>Continue working counter clockwise and pull one strand at a time up through the center of the knot. A scratch awl may be needed. Do this until all of the strands are through.</p>	
<p>Cut the ends even with top of the knot. The heel knot will be braided over this.</p> <p>Dampen the braids and roll them between two boards.</p>	

## Braiding Snaffle Bit or Training Reins

<p>Arrange the cord in your hand as shown in Figure 1. If rawhide or leather is used, the rough side should face the center of the pile. Secure this with a piece of wire, 5 cm (2") from the end of the strings. Divide the bundle in two. Hang this on a nail on a wall.</p>	 <p>Figure 1</p>
<p>To start the braid across the top left strand (#1) over the top right strand (#2).</p>	
<p>Continue working with the strands numbered as in Figure #1. Cross the second string on the right #3 over strand #1.</p>	
<p>Cross the second string on the left #4 over strand #3.</p>	
<p>Cross strand #5 over strand #4.</p>	
<p>Cross strand #6 over strand #5.</p>	
<p>Cross strand #7 over strand #6.</p>	

<p>Cross strand #8 over strand #7.</p>	
<p>Continue the braid with four more strands (strands 1-4 braided again) by reaching behind the braid. Pull strand #2 behind the braid to the right side. Weave it under strands #1 and #4 and over strands #6 and #8.</p>	
<p>If you have a core for your bosal, put it into the center of the braid.</p>	
<p>Continue to braid. Pull strand #1 behind the braid to the left side. Weave it under strands #3 and #5 and over strands #7 and #2.</p>	
<p>If more than 8 strands are used you change your weaving pattern. For 12 strands it will be over 2, under 2, over 2. With 16 strands it will be under 2, over 2, under 2, over 2.</p>	

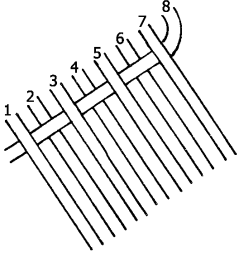
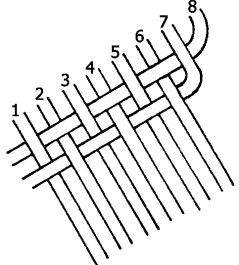
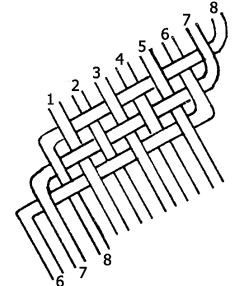
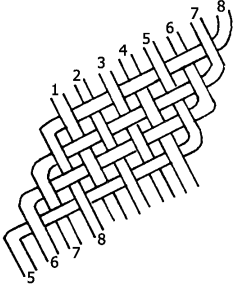
<p>Braid 10 inches. When this is done, tighten a piece of strong wire around the end of the braid. Tighten another piece of wire just below the nail the braid is hanging from. This keeps the braid from coming loose.</p>	
<p>Dampen the braid then roll it between two boards to make it round.</p>	
<p>Take strand #8 and weave it over and under the other strands. (If you prefer, start with strand #1 and work from left to right). Pull strand #8 tight against the braid below the wire.</p>	
<p>Take strand #7 and weave it over and under the other strands (over #8, #5, #3, #1, under #6, #4, #2, #8). Pull strand #7 tight against strand #8.</p>	
<p>Take strand #6 and weave it over and under the other strands. Pull strand #6 tight against strand #7.</p>	
<p>Take strand #5 and weave it over and under the other strands. Pull strand #5 tight against strand #6.</p>	

Take strand #4 and weave it over and under the other strands. Pull strand #4 tight against strand #5. Continue weaving until 2 m (6.5 feet) are completed.

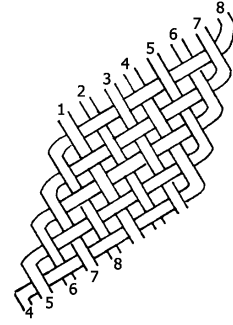

To finish the braid, weave each strand back into the braid for 5 cm (1.5 inches).

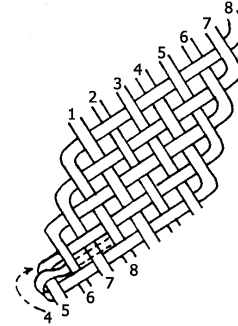

The reins may be used with the strands braided back in, or the following ends may be attached. Figure 20 is sewn over the rein ends. This is a piece of leather 14 cm (5.5 inches) long and as wide as your braid. Fold it over the end of the braid and sew it on.

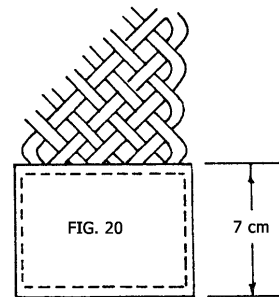
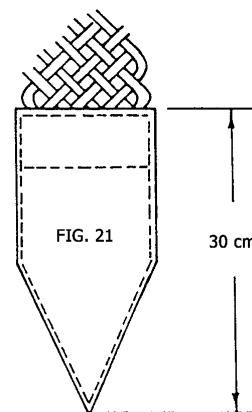

Figure 21 is cut as two pieces that are sewn together. The leather will overlap the braid, with one piece sewn on each side.



## MINERAL AND SALT FEEDER

### Lumber:

Sides	2 pieces 1" x 6", 3' 8" long
Ends and Divider	3 pieces 1" x 6", 2' 2" long
Bottom	8 pieces 1" x 6", 2' 3 1/2" long
Braces	4 pieces 1" x 6", 1' 7 1/2" long
Roof	11 pieces 1" x 6", 6' 0" long
Legs	4 pieces 2" x 4", 4' 8" long
Crosspieces	2 pieces 2" x 4", 2' 2" long
Rafters	4 pieces 2" x 4", 2' 4" long
Blocks	2 pieces 2" x 4", 6" long

### Note:

Lumber sizes listed are nominal sizes. Sizes available locally may be substituted. Roof must be waterproof. Cover roof boards with suitable roofing material, or build to suit. To hold feeding box in place, drive 2 X 4 inch stakes into the ground and nail to the legs.

*Feeding Plan by Sterling Salt Co.*

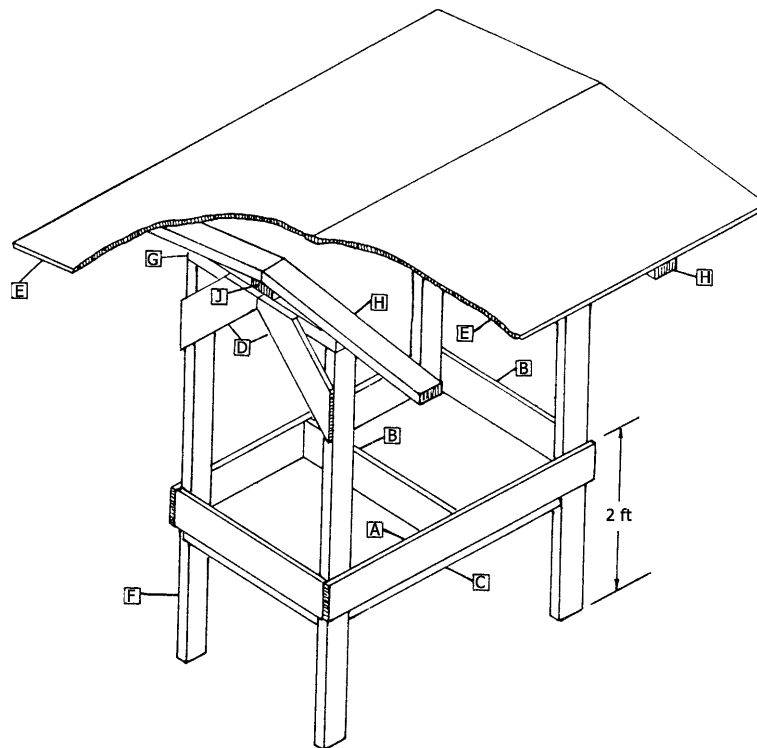

# CAVALETTI

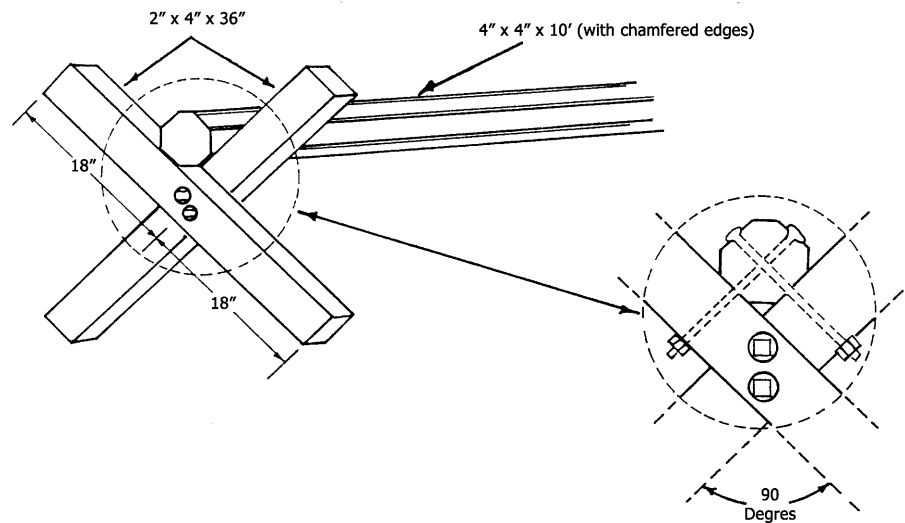

## Materials:

- 1 - 4" x 4" x 10'
- 4 - 2" x 4" x 36"
- 4 - 3/8" x 8 1/2" Carriage bolts
- 4 - 3/8" x 4 1/2" Carriage bolts
- 8 - 3/8" Flat washers

*Prepared by: R. C. Church - Extension Horse Specialist, University of Connecticut; Storrs, Connecticut*

## Cavaletti Construction:

The use of cavaletti originated with the Italian cavalry officer, Captain Caprilli. The father of forward seat riding, Caprilli worked horses at the trot and canter over wooden rails of varying height in order to increase the horse's balance and muscular development. These wooden rails secured on firm low stands served as the first cavaletti.

Rails used in the construction of cavaletti should be thick, round, and hard so they will not splinter when hit. Rails should be uniform in length, preferably from 6 to 9 feet. The longer the rail, the more difficult it is to keep the horse traveling on a straight line when working through a cavaletti series. Each rail should be secured in a low crossed end piece that forms an X to enable the cavaletti to be rotated to three different heights. Proper construction allows the use of a ground pole; trot pole, 6" to 8" in height; and a cantering pole, approximately 18" in height. Creative use of 6 to 9 cavaletti can provide sufficient gymnastic exercises for horse and rider at the walk, trot, and canter.

Caveletti are usually painted white. A wide band of color, red, blue, or green can be painted in bands in either side of the center to aid the horse in traveling on a straight line through the complete cavaletti series.

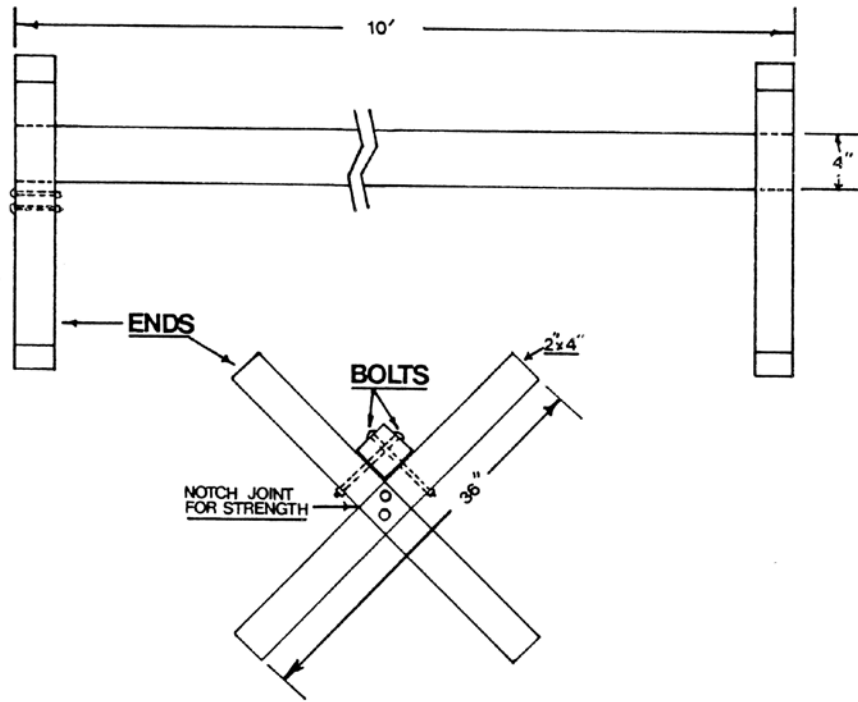

---

## HUNT SEAT PADS

---

The double pad is a little easier to put together. The pad with facing is easier for beginning riders to get the saddle in the right place on the pad and will be softer against the horse.

### Double Pad

#### Materials:

**Outer fabric** 0.9 meters (1 yard) of 115 cm (45") wide fabric. Suggested fabrics are heavy felt, sherpa, fleece, or fake fur. It must be machine washable. Choose a color that will look good on your horse and coordinate with your riding clothes.

**Backing fabric** 1.8 meters (2 yards) of 150 cm (60") wide non-woven polyester fleece.

**Thread** 1 spool of color to match the outer fabric.

#### Supplies:

Large disposable paper tablecloth

Soft pencil or felt tip marking pen

Measuring tape or short ruler

Straight pins (extra long ones are helpful on thick fabrics)

Scissors

Yard or meter stick

Sewing machine

Masking tape

#### Procedure:

1. Open the paper tablecloth flat and spread it smoothly on your horse's back. Put your saddle on top of the tablecloth, making sure there are no wrinkles in it. Trace around the edge of the saddle with the pen or pencil. Remove the saddle and tablecloth from your horse.
2. Put the tablecloth on a big, flat surface. Using the measuring tape or ruler, make the outline of the saddle 9 cm (3 1/2") larger. Cut this large shape out of the tablecloth - this is the pattern.
3. Fold the backing fabric in half. Using the yard or meter stick, draw a line from the opposite corners, making a large "X" across the fabric. Stitch on these lines with the sewing machine. Now stitch 5 cm (2") on either side of these lines until you have quilted the entire piece. Use the quilting guide on your sewing machine if you have one. If not, you will need to draw the lines using the yard or meter stick.
4. Center the pattern on the fabric you have just quilted. (See diagram). Pin the pattern in place and carefully cut it out. Remove the pattern.

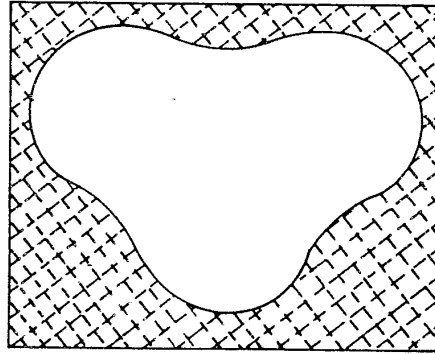

5. Center the pattern on the outer fabric, pin it in place, and carefully cut it out. Remove the pattern from the fabric.
6. With the right side of the fabric facing the quilted backing, match the edges of the two pieces together and pin in place.
7. Stitch around the outside, 1.3 cm (1/2") from the edge. Leave about a 23 cm (9") opening along one long side. Be sure to backstitch on either side of the opening.
8. Clip or notch the curves where necessary to make smooth seams. If very thick, bulky fur is used, it may be desirable to trim some of the pile out of the seam allowance.
9. Turn the pad right side out through the 23 cm (9") opening. Turn the edges of the opening 1.3 cm (1/2") to the inside, match and pin the folded edges, and stitch together 6 mm (1/4") from the edge on the sewing machine or blind stitch together by hand.
10. To hold the two layers together, stitch around the pad 7.5 cm (3") from the edge. To do this, put a piece of masking tape 7.5 cm (3") to the right of the sewing machine needle on the flat bed of the machine. Use the tape as a guide when stitching.

## Pad With Facing

### Materials:

**Fabric** 0.9 meters (1 yard) of 150 cm (60") wide fabric. Suggested are sherpa, fleece, heavy felt, or fake fur. Fabric must be machine washable. Choose a color that will look good on your horse and coordinate with your riding clothes.

**Thread** 1 spool to match fabric.

**2.5 cm (1") Twill tape** 0.9 meters (1 yard)

### Supplies:

The same supplies as are needed for the Double Pad.

### Procedure:

1. Make a pattern for the pad following the directions for the Double Pad, steps 1 and 2.
2. Center the pattern on the wrong side of the fabric and pin it in place. Trace around the

outside edge of the pattern with the pencil or marking pen, then remove the pattern from the fabric.

3. To make the pattern for the facing pieces, start with the paper pattern of the pad. Cut along the line that marks the original outline of the saddle; throw away the center heart shaped piece and save the larger outer ring.
4. With the pencil and yard or meter stick, draw dividing lines on the pattern like the diagram shows. Mark a number on each pattern piece.

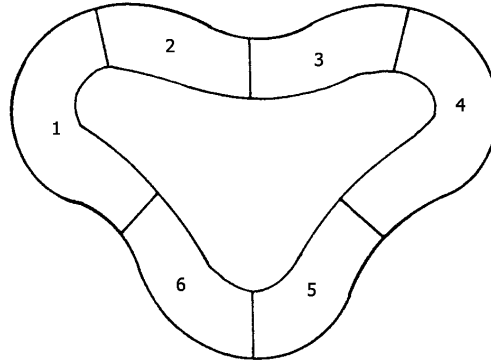

5. Cut the facing pattern into six pieces. On each new cut edge, tape a piece of paper 1.3 cm (1/2") wide. This adds a seam allowance to all these edges so you can sew the pieces back together again.
6. Put the facing pieces around the pad piece drawn on the fabric as shown in the diagram and pin them in place.

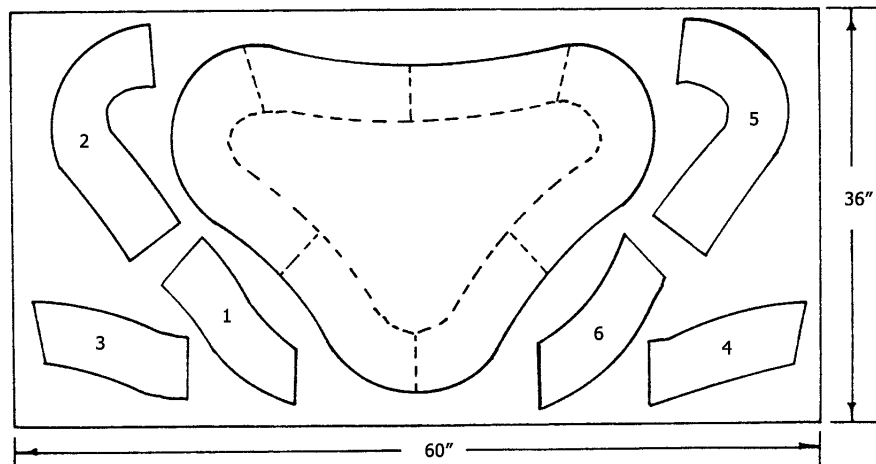

7. Cut out the fabric pieces for the pad and facings. Leave all the patterns pinned to the fabric until you are ready to sew them together.
8. Lay out the facing pieces so they match the outline of the pad. Then, one at a time, remove the pattern pieces and pin together the ends that are next to each other. Be sure to match the straight ends, with the right sides of the fabric together.
9. Stitch all six seams on the facing, sewing 1.3 cm (1/2") from the edge and

backstitching at the beginning and end of each seam.

10. Trim the corners of the seam allowances. If very thick, bulky fur is used, trim some of the pile out of the seam allowance.
11. Match the facing to the pad, with the right sides of the fabric together. Pin in place and stitch all around, 1.3 cm (1/2") from the outer edge.
12. Clip or notch the curves where necessary to make smooth seams. Trim away pile in the seam allowances to reduce bulk.
13. Turn the facing to the right side, flatten it to the pad, and pin the inner edges in place.
14. Stitch the facing to the pad using a zigzag stitch at the inside edge of the facing. Or stitch on the facing 6 mm (1/4") from the inside edge and then again 1.3 cm (1/2") from the edge.
15. Prepare twill tape. Cut two pieces of twill tape 35.5 cm (14") long.
16. Turn under cut ends 6 mm (1/4"). Pin in place to hold temporarily.
17. Make a firm loop on one end of each piece of tape by folding back one end 5 cm (2"). Pin and machine stitch across tape. Repeat 6 mm (1/4) from first stitching to secure end in place.
18. Stitch opposite end of tape to pad 12.5 cm (5") from center back of pad and 15 cm (6") from edge of pad.

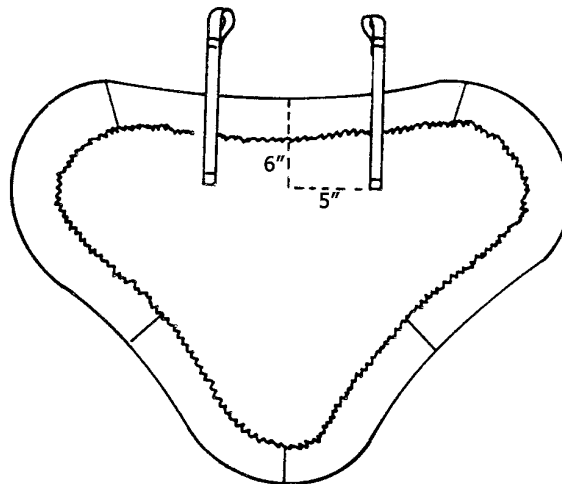

## MAKING A HORSE HALTER

An interesting and useful winter project is the construction of a rope halter. The project can be made at a very low cost, since the only material needed is nylon twine. Used nylon bail ties are also suitable, if chosen carefully.

This rope halter has two basic types of braiding or plaiting: round and flat. Before starting the halter, you should practice both types.

Begin by using two strands. Place them over a ring or hook fastened to something solid. For practice, rough binder twine is sufficient. Try to avoid using the same ties as you plan to use for the halter. After being worked, the ties will twist and are difficult to braid a second time.

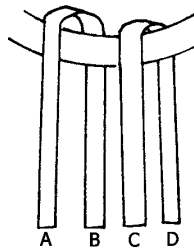

### Flat Braiding

<p>Begin by first crossing the two center strands. (C over B). Then bring B over D.</p>	
<p>Flat braiding is worked from the far left to the right. Starting with the far left strand A, weave it over C, under D over B.</p>	
<p>Strand C is now the far left, weave it to the right, over, under, over.</p>	

Continue by always working the far left strand to the right, weaving it over one strand under another, and over the third.

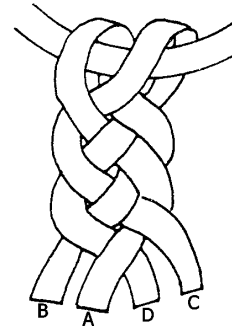

### Round Braiding

Round braiding may be a little more difficult than the flat plait. Alternate strands are brought around to the rear instead of straight across the front, as in flat braiding. When practicing, use two different colors.

Begin by crossing the two middle strands. Bring A to the right over B, and carry B toward the left.

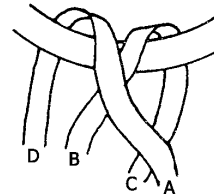

Bring D around to the rear, under C and over A.

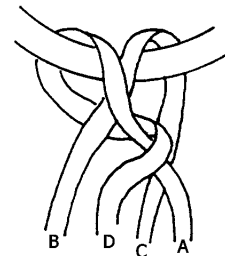

Bring C around to the rear and back again to the front, passing under B and over D.

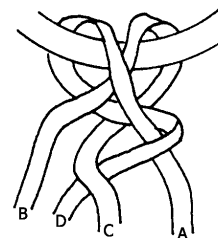

Strand B is worked next. Again bring it to the rear and back to the front under A and over C.

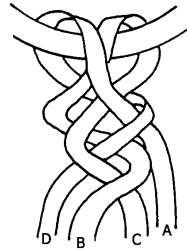

There are two strands on each side. Work alternately with the outer or upper ones, passing to the rear and following the sequence of under one strand over the next. Work the braid carefully, keeping it closed up. Unless the same amount of pull is used on each strand, the finish braid will look uneven.

## Constructing the Rope Halter

The entire halter requires 20 ties approximately 10 feet in length. Two ties are used for each strand.

### Begin with the Nose Band:

Use 8 ties (4 strands). Begin the center of the strands and flat braid approximately one foot. Clamp a clothespin on each end of the braid.

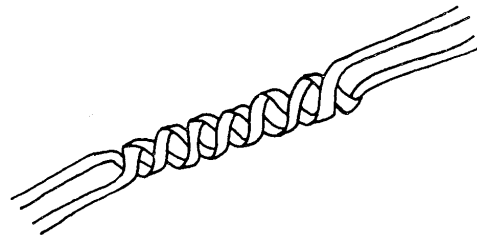

Weave two strands into each end of the flat braid, as shown above.

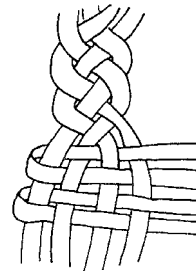

### From the Nose Band, Work on the Right Side:

Flat braid the right side piece approximately 9”.

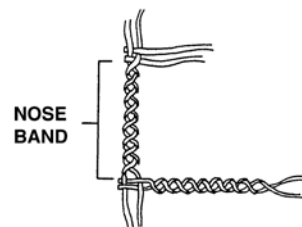

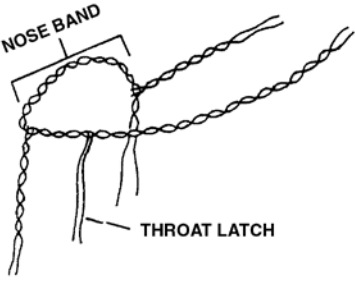
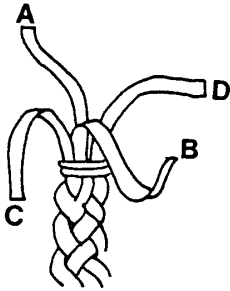
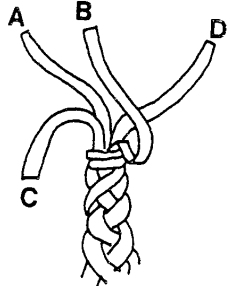
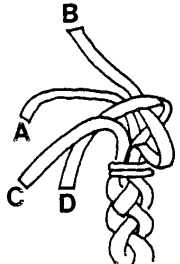
<p>Weave another 2 strands into the right side piece. These 2 new strands will form the throat latch. Continue braiding the right side piece for another 1 1/2 feet and tie a Turks' Head Knot.</p>	 <p>A line drawing of a horse's head in profile, facing right. A braided nose band is shown around the horse's nose. Two braided strands extend from the nose band down the horse's throat, labeled as the throat latch. The labels 'NOSE BAND' and 'THROAT LATCH' are placed near their respective parts.</p>
<p>To tie a Turks' Head Knot, lash the strands together and turn the ends upward.</p>	 <p>A diagram showing four strands of rope, labeled A, B, C, and D, emerging from a central point. Strands A and C are on the left, and B and D are on the right. The strands are being prepared for the first step of the knot.</p>
<p>Fold strand B over D leaving a bight in B where it is lashed.</p>	 <p>A diagram showing the four strands A, B, C, and D. Strand B is now folded over strand D, creating a loop or bight in strand B. Strand C remains on the left.</p>
<p>Fold strand D over both B and A, also leaving a bight in D.</p>	 <p>A diagram showing the four strands A, B, C, and D. Strand D is now folded over both strands B and A, creating a bight in strand D. Strand C remains on the left.</p>

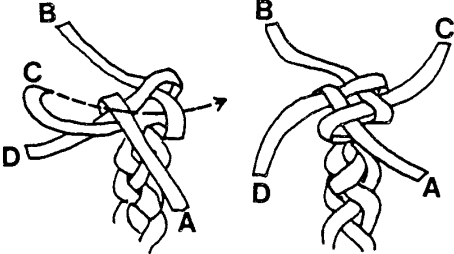
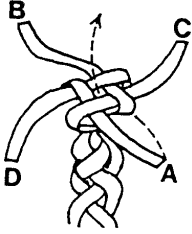
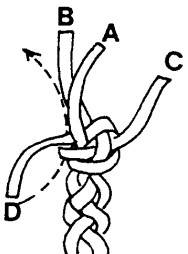
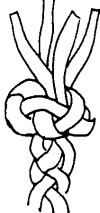
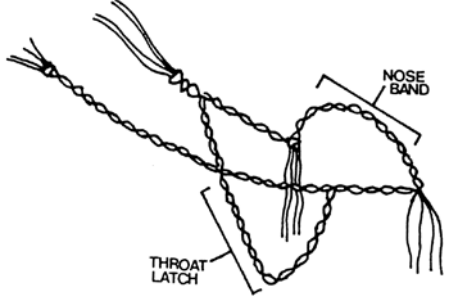
<p>Pass A over D and C. Then thrust C over A and through the bight in B, as indicated by the arrow line.</p>	
<p>Continuing in the same direction, which in this case, is counter clockwise, pass A around and to the outside of the bight of B and up under B and C. This strand emerges in the center of the braid as indicated by the arrow line.</p>	
<p>Pass D around and outside of the bight of C and then up through the center under C and A.</p>	
<p>Work the knot tight, but be sure to press it back on the braid or it will be inclined to slip upward. Continue working counter clockwise and bring B and C up through the center in the same manner.</p>	
<p><b>From the Nose Band, Work on the Left Side Piece:</b></p>	
<p>Flat braid the left side piece approximately 9". Flat braid the throat latch piece approximately 19".</p>	
<p>Join the left side piece of the throat latch, and start a round braid. You are now working with 16 ties - 4 ties per strand.</p>	

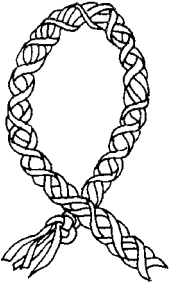
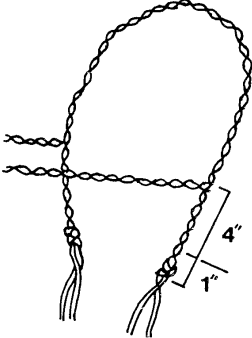
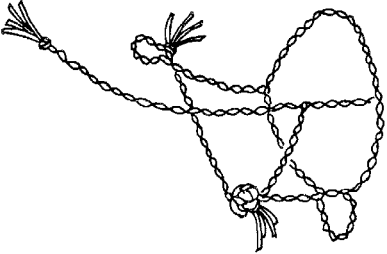
<p>Round braid approximately 7". Make a loop in the braid and slip it back through itself, just passed the join. Tie a second Turk's Head Knot.</p>	
<p><b>Make the Halter Shank Loop:</b></p>	
<p>Working on the remaining portions of the noseband, flat braid approximately 4" beyond the side piece joins. Then round braid 1" on each side.</p>	
<p>Join the two side pieces and continue round braiding another 7". Make a second loop similar to the one made on the left side piece, slipping the braid back through itself at the join.</p> <p>Braid round for another 8". Make a third loop through the throat latch and tie another Turk's head knot.</p>	

Your halter is completed.

This rope halter is designed for a mature light horse. However, the pattern can easily be altered to fit a younger horse or foal, as well. In addition leather lacing or synthetic cord could be used to make a more attractive halter.

---

# TACK BOX

---

## Small Tack Box #1

24 x 16 x 12 inches

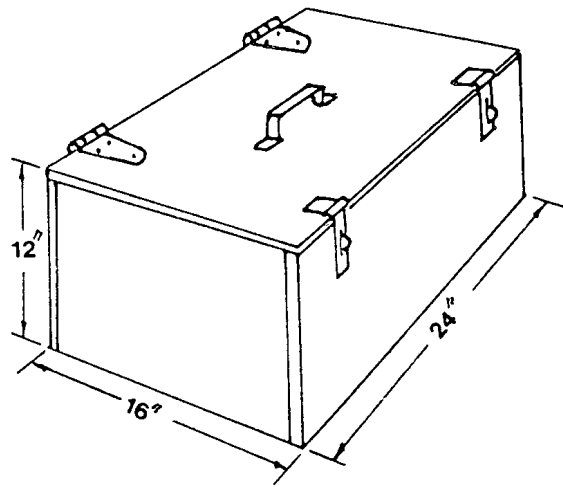

### Materials:

- 1 sheet (4' x 4') 1/2" plywood
- 2 hasps
- 1 handle
- 2 hinge straps
- Wood screws
- Finish nails

### Equipment:

- Pencil
- Ruler or measuring tape
- Saw
- Screwdriver
- Drill
- Vise
- Sander

**Steps:**

1. Mark the sheet of plywood as shown below.

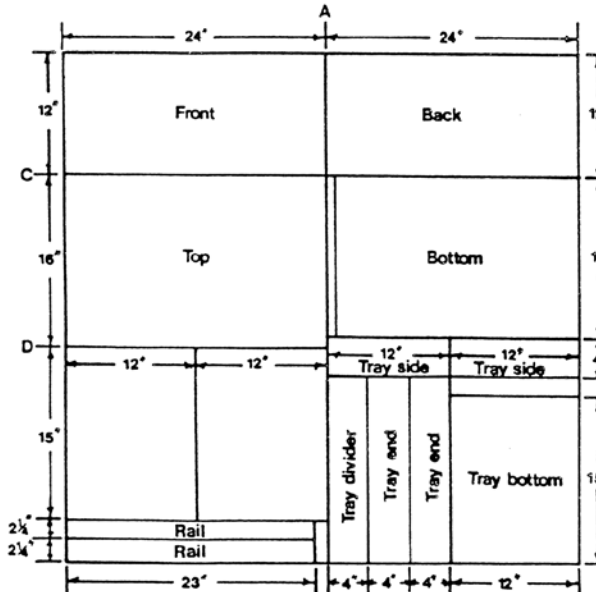
**Method:**

- a. Mark the center of the board as shown below, lengthwise using the pencil or tape measure to draw dots.
- b. Connect the dots using a light pencil line.
- c. Mark then draw a line 12" from one end of the board.
- d. Mark and draw a line 16" below line "C" on the left side of the board.
- e. Mark and draw a line 15" below line "C" on the right side of the board.
- f. Mark and draw a line 4" below line "e".
- g. Draw a vertical line so section c-a-e measures (23" x 15").
- h. Divide the area e-a-f into two equal 4" x 12" areas and continue this line to the bottom of the board.
- i. Working in the lower right sections you have marked, divide the left half into 3 - 4" x 12" sections.
- j. The right lower corner needs one horizontal line to shorten it to 15 3/4" (15 3/4" x 12").
- k. The lower left hand board has another horizontal line drawn 15" from line 'd'.
- l. The bottom 4 1/2' of the board has another horizontal line drawn at 2 1/2".
- m. These 2 1/4" section need a vertical line through them so they will measure 23" in length.
- n. The section between lines 'd' and 'j' is divided in half (12" x 15").

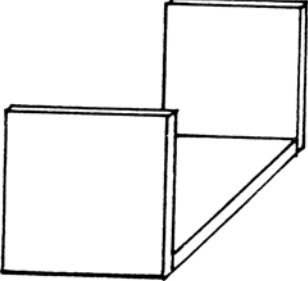
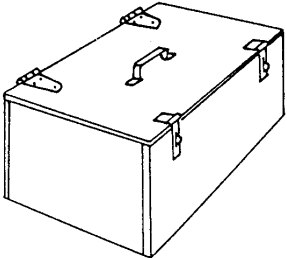
<p>2. Cut the board into the desired pieces using the saw.</p>	
<p>3. Using glue, attach the end pieces to the box bottom.</p> 	<p>a. Allow the glue some time to dry before setting the pieces together. The glue should feel practically dry.</p> <p>b. Secure the pieces with nails or screws. (If you are using screws, you must drill a sink hole. This must be smaller in diameter than your screw, or it will not hold).</p>
<p>4. Attach the sides using the same procedure.</p>	
<p>5. Attach the rails to the front and back piece with glue, then nails or screws. The rails should be 4" - 6" below the lid.</p>	
<p>6. Attach the side and end pieces to the tray using glue and screws as in steps 3a and 3b.</p>	
<p>7. Place the tray divider in the tray. Attach it with screws or nails. This may be centered, or off to the side.</p>	
<p>8. Sand the edges and outside of the box. Paint or stain the wood.</p>	
<p>9. Attach the lid.</p>	<p>a. Set the lid evenly on top of the box.</p> <p>b. Take the hinges and mark their location on the box and lid. Mark the nail or screw holes in them.</p> <p>c. Lift the hinges and drill holes for the screws where you have marked them.</p> <p>d. Attach the hinges.</p>
<p>10. Attach the handle.</p> 	<p>a. Locate the center of the lid.</p> <p>b. Center the handle over your marks.</p> <p>c. Drill holes for the screws.</p> <p>d. Attach the handles.</p>

## Large Tack Box #2

1 1/2 x 2 x 4 feet

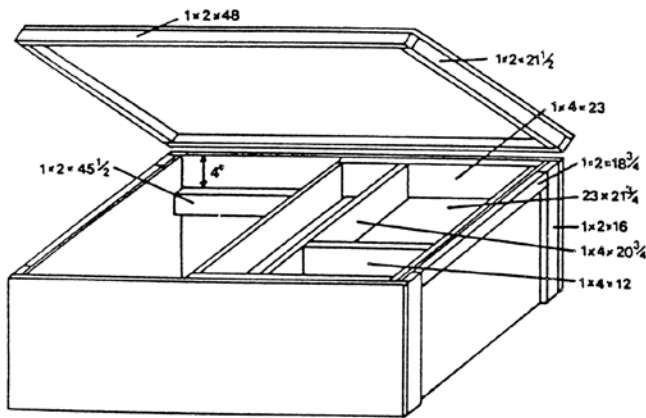

### Materials:

- 1 - 1" x 4" x 10' pine s4s
- 4 - 1" x 2" x 10' pine s4s
- 1 - 4' x 8' x 1/2" exterior grade fir plywood
- 1 - 2' x 2' x 1/4" interior grade fir plywood
- Water resistant glue
- Screws or finish nails
- Paint or stain
- 2 hinges
- 2 handles
- 1 fastener

### Equipment:

- Pencil
- Ruler or measuring tape
- Saw
- Sander
- Screwdriver
- Drill
- 4 wood vises
- 1 bench vise

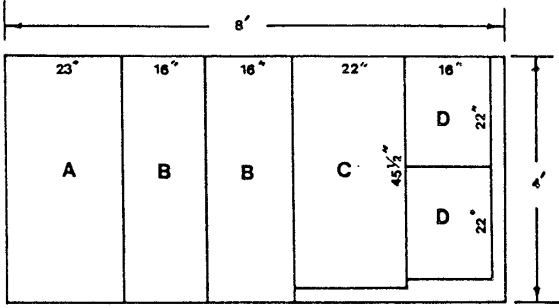
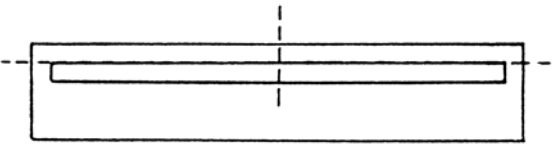
Steps	Method:																												
<p>1. Mark the sheet of 1/2" of exterior grade as shown.</p> 	<p>Using a pencil and yard or meter stick, measure and draw lines follow the pattern.</p>																												
<p>2. Cut the board into the desired sizes.</p>	<p>For "c" and "d" cut to the end of the board instead of trying to make the corners meet.</p>																												
<p>3. Cut the 1 x 2 x 10 pine s4s as follows.</p>	<p>Care needs to be taken when cutting or the lengths will not be accurate.</p>																												
<table border="1" style="width: 100%; border-collapse: collapse;"> <tbody> <tr> <td style="text-align: center;">18.75</td> <td style="text-align: center;">18.75</td> <td style="text-align: center;">18.75</td> <td style="text-align: center;">18.75</td> <td style="text-align: center;">21.5</td> <td style="text-align: center;">21.5</td> <td style="text-align: center;">2" waste</td> </tr> <tr> <td colspan="2" style="text-align: center;">48</td> <td colspan="2" style="text-align: center;">48</td> <td style="text-align: center;">16</td> <td style="text-align: center;">8</td> <td style="text-align: center;">8" waste</td> </tr> <tr> <td style="text-align: center;">16</td> <td colspan="2" style="text-align: center;">45.5</td> <td colspan="3" style="text-align: center;">45.5</td> <td style="text-align: center;">13" waste</td> </tr> <tr> <td colspan="2" style="text-align: center;">45.5</td> <td colspan="2" style="text-align: center;">45.5</td> <td colspan="3" style="text-align: center;">29" waste</td> </tr> </tbody> </table>		18.75	18.75	18.75	18.75	21.5	21.5	2" waste	48		48		16	8	8" waste	16	45.5		45.5			13" waste	45.5		45.5		29" waste		
18.75	18.75	18.75	18.75	21.5	21.5	2" waste																							
48		48		16	8	8" waste																							
16	45.5		45.5			13" waste																							
45.5		45.5		29" waste																									
<p>4. Assemble the box.</p>	<ol style="list-style-type: none"> <li>Attach the 1" x 2" x 18 3/4" and 1" x 2" x 16" strips to the end pieces (16" x 22").</li> <li>Glue the 1 x 2 to the plywood.</li> <li>Drill holes for the screws.</li> <li>Secure with screws.</li> </ol>																												
<p>5. Attach the tray support to the sides.</p> 	<ol style="list-style-type: none"> <li>Measure and draw a line 4" down on the long side of piece "B." One line on each board.</li> <li>Mark the center.</li> <li>Take the 2 - 1" x 2" x 45 1/2" boards and mark the center.</li> <li>When the glue on the boards is dry enough to attach, line up the center mark on the strips.</li> <li>Drill holes for screws.</li> <li>Secure the screws. (They should not show on the outside of the box).</li> </ol>																												

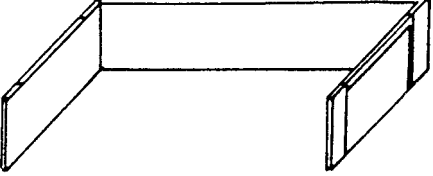
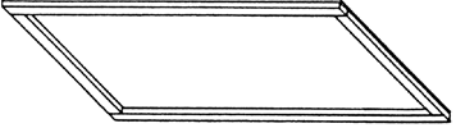
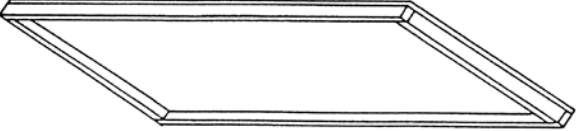
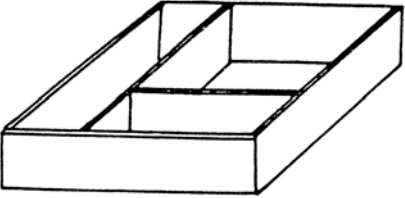
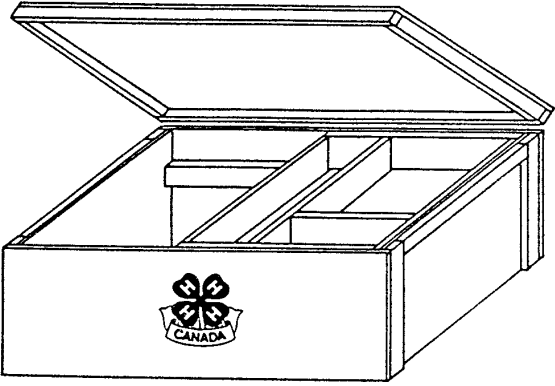
<p>6. Attach sides to end pieces.</p> 	<p>a. Use glue to attach. b. Drill holes for screws. c. Secure with screws.</p> 
<p>7. Attach the 45 3/4" and 18 3/4" inch strips to piece "c".</p>	
<p>8. Turn the box upside down and attach the bottom using screws.</p>	
<p>9. Attach the 48" and 21 1/2" strips to the lid (piece "A").</p> 	<p>The narrow strip (1") of the strip rests against the lid.</p>
<p>10. Assemble the sliding tray.</p> 	<p>a. Use the 2' x 2' interior grade fir plywood for the tray bottom. b. Attach the 23 and 21 3/4" 1" x 4" to form the sides. c. Arrange the remaining tray.</p>
<p>11. Sand the outside of the box and tray and the edges.</p>	
<p>12. Paint or stain the box and tray. You can decorate your box by adding your name, your club name and/or a 4 - H emblem.</p>	
<p>13. Take the hinges and place them on the lid and box (they should be the same distance from the corners). Mark the spaces for screws. Attach the hinges.</p>	
<p>14. Attach a latch to the center front of the box.</p>	
<p>15. Attach handles to the sides of the box.</p>	

---

## DESIGNS BASED **ON WORK BY:**

---

Club Banner	Arlene Vrooman
Western Saddle Pad 1	Arlene Vrooman
Breast Plate, etc.,	Arlene Vrooman
Tack Covers	Cornell University
Cooling Sheet	Cornell University
Leg Wraps 2	Cornell University and Nancy Crisman
Cavaletti	R.C. Church
Cavaletti Construction	Diane Soloman
English Saddle Pads	Arlene Vrooman

